

ENGLISH

Class IX (2026-27)

Introduction

At the secondary stage, language learning strengthens the learners' abilities to use language meaningfully for comprehension, expression, interpretation, and critical engagement with texts. Pedagogical processes emphasise dialogic reading, reflective writing, listening, and speaking activities, and contextual use of language through discussion, interpretation, and creative expression. Assessment focuses on understanding, interpretation, communicative clarity, articulation of ideas, and the ability to analyse and respond to texts in multiple modes, rather than only on recall-based written responses.

As per NCF-SE 2023, language education at the Secondary Stage must specifically aim to achieve:

- (a) **Oracy and literacy:** Oracy and literacy are fundamental to school education.
 - Attaining oracy means students develop fluency in expression and understanding of spoken language.
 - Literacy means that all students demonstrate fluent and critical reading, writing, and comprehension capacities in the language.
- (b) **Effective communication skills:** Students may develop their language capacities to think critically, identify real-world problems, analyse them, make rational arguments, work out solutions and communicate well in a variety of situations for effective democratic, social, and cultural participation.
- (c) **Literary and creative capacities:** Language teaching in schools must aim at building capacities in students towards an appreciation of the literary aspects of language. It may also allow for an exploration of—how to be creative and imaginative in their spoken and written expressions across cultures.
- (d) **Appreciation and engagement in culture:** Learning a language is learning a culture. Thus, language plays an important role in the immersion and participation in culture. Students must be allowed to understand and appreciate the rich linguistic cultures of India.
- (f) **Linkages with the Indian Knowledge System:** Along with the development of skills and competence, other aspects such as emotional intelligence, social feeling, national pride, connections of art, social concerns, and natural science are addressed through content, context and pedagogy with the focus on fundamentals of literature and life (critical thinking), such as emotion, perception, feeling, sound, language, thought, memory, metaphor, aesthetics, environment, self, society, culture, civilisation, etc.

Language Learning Approach

Experiential, activity and discussion-based approaches are recommended to promote the culture of self-learning and reduce dependence on the teacher. The teaching of language will be enhanced through innovative and experiential methods. Thus, the teaching of language will also be based on the experiential-learning pedagogy. The shift requires that students' contexts and experiences become part of the pedagogical processes.

Experiential learning includes any type of activity that comprises learning by doing, i.e., experimenting, exploring, sharing personal narratives, observing, cooperative learning, and above all, self-learning and self-assessment. Students need to have mastery in the 21st century skills, such as effective communication, critical thinking, creativity, collaboration, etc.

There are diverse learning situations and contexts in India. Language education plays a crucial role in keeping students rooted to their country, as it allows individuals to connect with their culture, heritage and society.

Learning Standards

Learning standards enable teachers to plan their content, pedagogy, and assessment towards achieving specific competencies. These must be seen as enabling guidelines for teachers and school leaders, not as constraining demands on them. By the end of the secondary stage, we would expect every student must have gained the whole range of skills and competencies. It is at this stage that using the language of students turns out to be more productive. Students use language to interpret, understand, address issues, and gain knowledge that will help them to become autonomous learners.

As per NCF-SE 2023, students will develop linguistic proficiency for academic use in R1 and R2 by the end of the secondary stage ensuring that a higher level of familiarity, understanding, and interpretation of literature is achieved.

Curricular Goals and Competencies-Secondary Stage

Curricular Goals (CGs) are specific statements derived from the broader Aims of Education that give clear direction to curriculum development and implementation. Competencies are the specific, observable, and systematically assessable learning achievements that students must attain by the end of the stage.

Language R1

Curricular Goal (CG)	Competency (C)
CG-1: Uses language for effective communication through writing various forms (essays, letters, articles, discussions, interviews, public speeches) and for new media (email, audio, and visual material).	<p>C-1.1: Uses language appropriate to social context, expresses agreement and disagreement with reasons, and arrives at conclusions through discussion and debate.</p> <p>C-1.2: Writes in different styles (narrative, descriptive, expository, persuasive) from their own experiences and experiences of others.</p> <p>C-1.3: Writes for real-life situations (invitations, speeches, condolence messages, notices, creative slogans, advertisements) and for school newsletter/magazine/journal.</p> <p>C-1.4: Scripts to inform and communicate ideas effectively with the use of technology.</p>
CG-2: Develops an appreciation of the aesthetics in different genres (humour, suspense, tragedy) through analysis of style (narrative, descriptive, expository, persuasive) and employs these elements in their writing.	<p>C-2.1: Describes characteristics of works of literature from different time periods (such as early, medieval, contemporary).</p> <p>C-2.2: Analyses a literary text by close reading, critiquing form and style, and interpreting possible meanings.</p> <p>C-2.3: Composes literary texts by using appropriate literary devices.</p>
CG-3: Uses language to develop reasoning and argumentation skills by engaging with a variety of audio and written material.	<p>C-3.1: Analyses and evaluates the different audio and written material.</p> <p>C-3.2: Argues with proper rationale by carefully evaluating premises.</p>
CG-4: Appreciates literary and cultural heritage in and related to the language and the richness of Indian languages.	<p>C-4.1: Recognises the multilingual nature of Indian society and richness of its literary work through reading texts and watching content of different genres.</p> <p>C-4.2: Appreciates the richness of culture and heritage in the different works of regional language literature and their connections.</p> <p>C-4.3: Shows an understanding of the role of language in the formation of our identities and culture.</p> <p>C-4.4: Demonstrates a basic knowledge of the commonalities among some of the major Indian languages, such as their common phonetic and scientifically arranged alphabets and scripts, common grammatical structures, origins and</p>

Curricular Goal (CG)	Competency (C)
	<p>sources of vocabularies from Sanskrit and other classical languages.</p> <p>C-4.5: Demonstrates a basic knowledge of which languages are spoken in which geographical areas, a sense of the nature and structure of tribal languages, and becomes familiar with a few useful words and phrases and works of literature from a few Indian languages from across the country.</p>

Language R2

Curricular Goal (CG)	Competency (C)
<p>CG-1: Uses language for effective communication through various oral activities (discussions, interviews, public speeches) and writing activities (essays, letters, articles), including new media (email, audio, and visual material).</p>	<p>C-1.1: Uses language appropriate to social context, expresses agreement and disagreement with reasons, and arrives at conclusions through discussion and debate.</p> <p>C-1.2: Writes in different styles (narrative, descriptive, expository, persuasive) from their own experiences and experiences of others.</p> <p>C-1.3: Writes for real-life situations (invitations, speeches, condolence messages, notices, creative slogans, advertisements) and for school newsletter/magazine/journal.</p> <p>C-1.4: Scripts to inform and communicate ideas effectively with the use of technology.</p>
<p>CG-2: Uses language to develop reasoning and argumentation skills by engaging with a variety of audio and written material.</p>	<p>C-2.1: Analyses and evaluates different audio and written material.</p> <p>C-2.2: Argues with proper rationale by carefully evaluating premises.</p>
<p>CG-3: Develops an appreciation of the aesthetics in different genres (humour, suspense, tragedy) through an analysis of style (narrative, descriptive, expository, persuasive) and employs these elements in their writing.</p>	<p>C-3.1: Describes characteristics of works of literature from different time periods (such as early, medieval, contemporary).</p> <p>C-3.2: Analyses a literary text by close reading, critiquing form and style, and interpreting possible meanings.</p> <p>C-3.3: Composes literary texts using appropriate literary devices.</p>

FOCUS AREAS OF THE SYLLABUS

The syllabus aims to develop students' ability to use language effectively for communication, reasoning and creative expression. The curriculum focuses on strengthening Listening, Speaking, Reading and Writing skills while fostering literary appreciation and critical thinking. Students engage with a variety of texts and activities that promote analytical thinking, creativity, collaboration and real-life application of language skills.

Reading

By the end of the secondary stage, students should be able to:

- Read and comprehend a variety of literary and non-literary texts with understanding.
- Identify main ideas, supporting details and key information in written texts.
- Analyse, interpret and evaluate ideas presented in different texts.
- Distinguish between facts and opinions and identify cause–effect relationships.
- Infer meanings and draw conclusions from textual evidence.
- Understand the author's perspective, tone and style of writing.
- Interpret information presented in different forms such as diagrams, charts and tables.
- Connect ideas from the text with personal experiences and social contexts.
- Develop critical reading skills through close reading and discussion.
- Read independently and engage with texts from diverse cultures and contexts.

Writing

By the end of the secondary stage, students should be able to

- Write clearly and coherently using appropriate grammar, vocabulary and organisation.
- Write in different styles such as narrative, descriptive, expository and persuasive.
- Present ideas with a clear beginning, middle and conclusion.
- Describe experiences, events and observations in a logical manner.
- Express opinions and viewpoints with appropriate reasoning and examples.
- Write for real-life purposes such as notices, invitations, advertisements, speeches and messages.
- Gather ideas from different sources and organise them effectively in writing.
- Write reports, articles and pieces for school magazines, newsletters and journals.
- Use technology and digital tools to present ideas through written and visual formats.
- Review, edit and improve written work through feedback and self-assessment.

Listening & Speaking

Listening

By the end of the secondary stage, students should be able to

- Listen attentively to conversations, discussions and audio material.
- Identify the main ideas and important details in spoken texts.
- Analyse and interpret information presented through speeches, discussions and media sources.
- Distinguish between key points and supporting information.
- Understand instructions, explanations and viewpoints expressed by others.
- Note important details and organise information appropriately.

Speaking

By the end of the secondary stage, students should be able to

- Express ideas clearly and confidently in different situations.
- Present opinions, viewpoints and arguments with logical reasoning.
- Participate actively in discussions, debates and conversations.
- Communicate effectively in formal and informal contexts.
- Present ideas through speeches, presentations and oral reports.
- Respond appropriately to questions and viewpoints of others.
- Interact respectfully with others during discussions and collaborative activities.

Structures (Grammar) & Vocabulary

By the end of the secondary stage, students should be able to

- use the **sequence of tenses** correctly in different contexts of communication.
- identify and apply **modal auxiliaries** to express ability, obligation, permission, possibility, and advice.
- transform and use **reported speech** in extended texts including statements, questions, commands, and requests.
- construct sentences using **Conditional Clauses (Type 1)** to express real and possible situations.
- apply the rules of **subject–verb concord** to ensure grammatical accuracy in sentences.
- use appropriate **determiners** to provide clarity and precision in communication.
- identify and construct **clauses**, including **noun clauses** and **relative clauses**, to create complex and meaningful sentences.
- expand vocabulary through contextual reading and writing;
- understand meanings of unfamiliar words through context and reference tools such as dictionaries;
- use appropriate words and expressions to communicate ideas clearly;
- apply vocabulary effectively in speaking and writing tasks.

Grammar and vocabulary learning will be reinforced through editing tasks, sentence transformation, contextual exercises and communicative activities to promote accuracy and fluency in language use.

Literature — Prose & Poetry

By the end of the course, students should be able to:

- Read and appreciate a variety of literary texts from different genres.
- Analyse characters, themes and ideas presented in literary works.
- Interpret events, conflicts and relationships in stories and poems.
- Recognise the influence of context, culture and background on literary texts.
- Identify literary devices such as simile, metaphor, imagery, repetition and symbolism.
- Interpret meanings beyond the literal level through critical reading.
- Evaluate characters' actions and motivations.
- Express personal responses and interpretations through discussion and creative activities.
- Develop an appreciation of the aesthetic and cultural aspects of literature.

Pedagogy of Language

Pedagogy, at the secondary stage, should take into consideration the knowledge and capacities that students will bring from the previous stages of schooling. The pedagogy may encourage more self-study and exploration with a focus on becoming fluent in the methods of inquiry specific to the Curricular Area. At this stage, students can be reasonably expected to become independent learners and the pedagogy in the classroom may reflect this expectation.

Classroom interactions may be a judicious mix of more direct instruction from the teacher with discussion, seminars for discussion, exploration and discovery, and opportunities for students to prepare individual and group projects and present key concepts of the discipline.

Depending on the matter of study, context, and stage of the student, these effective pedagogical approaches would be of a wide range, including pedagogy that is more experiential, integrated, inquiry-driven, discovery-oriented, discussion-based, project-based, arts-based, sports-based, and activity-based. Effective pedagogy, therefore, encourages conceptual understanding, active discovery, questioning and debating, and independent learning. It gives serious consideration to student experiences and student voices, acknowledges and accommodates student diversity, builds on students' previous knowledge, uses a range of teaching techniques, and gives timely feedback on the work done. Classroom processes must encourage active learning with an emphasis on dialogue and building relationships based on mutual respect.

At this stage, the following may become part of the pedagogical process.

a) **Oral presentations:**

- I. Students must be given opportunities for sharing their ideas freely and listening to others' points of view. They must also ask questions, argue for their own views, and accept others' views with proper justification.
- II. Students must be taught focused dialogue and conversation which require organising their thoughts for better clarity, the art of raising relevant questions, brainstorming, and thinking aloud, active participation, and skills of literary appreciation.
- III. Teachers must use methods, such as role play, group discussion, debate, open house dialogue, and interviews to allow students to ask questions and learn to respond impromptu. Club-based activities, assembly gatherings, and celebrations in schools can be used as platforms to practise these methods and may not be seen as a separate exercise.
- IV. Teachers must also find ways to teach students how to work on their listening skills (by paying attention to details and summarising) and use the same in day-to-day life.

b) **Developing reading skills:**

- I. **Literary language skills:** Students can be encouraged to participate in group activities in critically analysing a literary text in the class and participate in the activities of the school literature club, poetry house, and fiction-reading groups.
- II. **Critical reading skills:** The teacher may focus on enabling students to make meaning of a variety of texts, move from initial impressions to a closer reading of the text by asking questions related to the effect of words and ideas expressed, and how the effect of the language used in a text is working for specific purposes.
- III. **Exposure to reading multicultural texts:** Activities such as the comparison of literary works of two different writers can be done effectively by inquiring into the author's voice, cultural background, and context of the work, and talking about other similar works in the genre. Projects, plays, folk music performances, and posters are important ways in which students in this stage can be introduced to texts from a different era. Multicultural texts may be available in libraries for students to read in their free time.

c) **Developing writing skills:**

- I. **Functional language writing skills:** Students may be given enough opportunity to practise writing reports, essays, notes, applications, letters to editors, advertisements, and notices. They can also be encouraged to write in magazines, newsletters, newspapers, and blogs.

II. **Literary language writing skills:**

- i. Students must be guided towards independent and creative writing in this stage. They must be taught capacities for analysing literature and connecting it to its historical and socio-economical aspects rather than reading it in isolation, enabling the writing of a critical review.
- ii. Teachers must ensure students practise writing poems, stories, or plays with literary devices (e.g., similes, metaphors, hyperbole, irony, puns, and oxymorons).
- iii. Teaching them to identify voice and style of a writer taking cues from the material they read will help them find their own voice.

Assessment

In alignment with NCF-SE 2023, assessment moves beyond measuring recall to evaluating students' ability to interpret ideas, communicate effectively, think critically, and engage meaningfully with texts and contexts. Assessments should be based on observations, portfolios, and projects and should not just focus on capacities and skills, but also values and dispositions.

Assessments need to be visualised as an ongoing process which teachers integrate within the teaching-learning process using formal and informal ways to elicit reliable evidence about student learning. Assessment may not become an intimidating process that involves the labelling and segregation of students.

The 'assessment culture' must change, so that assessment is conducted increasingly as learning and for learning. There must also be periodic assessment of learning to ensure readiness for the next phase of learning and to arrange suitable support for students when this readiness is not achieved.

Assessment should emphasize a balanced approach integrating three dimensions:
Assessment of Learning; Assessment for Learning; Assessment as Learning

Assessments could be formative or summative, and both are important for improving teaching and learning.

a) **Formative Assessment**

- I. Formative assessments at secondary stage will continue to be competency-based, covering all dimensions of learning. Therefore, various formative assessment techniques, such as projects, debates, presentations, discussions, experiments, investigations, role plays, journals, and portfolios, should be used to assess learning.
- II. Regular assessments comprising MCQs and constructed responses (e.g., short answer and long answer), with the aim to test conceptual understanding and higher-order capacities rather than merely rote learning.
- III. Classroom and Self-assessment will play a key role in student learning at this stage.

- IV. Assessments can be designed using case-based questions, simulations, and essay-type questions to enable the assessment of competencies in order to continually replan and revise the teaching-learning process.

b) Summative Assessment

Summative examinations, including certification examinations, continue to be relevant as they serve as a necessary test to understand students' achievement of competencies and learning standards.

- I. At the end of each year (or term), there will be a comprehensive summative assessment, which in relevant cases, would be the Board examinations.
- II. Assessment may measure the achievement of competencies and learning standards leading to the attainment of Curricular Goals. The connection between the competencies or Learning Outcomes and the assessment should be clear and precise.
- III. Appropriate forms of assessments may be chosen in alignment with the competencies and learning standards to be assessed.
- IV. Assessments should be constructive, developmental, and learning focused.

Forms of Assessment

There are several forms of assessment that can be used across both formative and summative assessments.

(a) Written Tests: Forms of written tests include:

- I. **Objective Type Questions:** These include Multiple Choice Questions (MCQs), filling in blanks, matching, sorting lists based on select criteria, picking the odd one out, labelling a diagram, solving a crossword, unscrambling a word, solving riddles and word grids that require a very short or one-word answer.
- II. **Constructed Response Questions:** These are questions that require students to frame and write answers. They can be close ended (requiring one correct and short answer) or open-ended (requiring a short or long essay with multiple correct/alternate answers).
It is important to have clear and detailed scoring guides/marketing schemes for such questions to avoid subjectivity in assessment.
- III. **Graphic Organisers:** These visual representations of ideas and concepts help students organise their learning and assimilate new knowledge.

(b) Oral Tests: The most common forms are reading aloud, responding to questions, recitation, and debates and discussions. Other forms, include group discussions, presentations, and extempore talks.

- I. **Reading Aloud:** Reading assessments could include reading aloud a passage, a poem, or any other form of writing. Word recognition, fluency,

and voice modulation skills could be assessed along with comprehension by asking students to summarise or talk about what they have read.

- II. **Listening and Responding:** Students listen to a text and respond either orally or on a worksheet.
- III. **Recitation:** This helps the teacher assess the spoken language with a specific focus on pronunciation, intonation and comprehension by observing students' expressions and actions.
- IV. **Debates and Discussions:** Students' fluency of language as well as proficiency in making strong arguments using knowledge and reasoning to persuade and convince the audience can be assessed while also developing an ability to understand and respect others' viewpoints and opinions. Teachers can also include other parameters, such as diction department, ability to take criticism positively, and manage their emotions and body language during public speaking. Sharing parameters before setting the task helps students focus on developing these skills which serves as good learning opportunities as well.

Practical Tests

These require students to demonstrate specific skills and applications of their new learning. These include :

- I. **Projects:** Projects are longer, structured activities completed by individual students or groups of students that result in a product. For example, a model, a substantial report, or a collection of artefacts. While doing projects, students investigate, explore, and respond to complex questions, real-world challenges, and problems. Projects help assess collaboration, communication, perseverance, creativity, and problem solving along with assessing subject-specific knowledge and skills.
- II. **Portfolios:** A student portfolio is a purposeful collection of student work that tells a story about a student's efforts, progress, and achievement in one or more subjects over a period of time. It could be a collection of the student's day-to-day work or a selection of the student's best pieces of work. Portfolios may include writing samples, laboratory reports, journals, artwork, short surveys and research papers, projects, photos, worksheets, tests and map work, Teacher's qualitative comments on the students' work, peer feedback, and the students' own reflections on their learnings.

It becomes a cumulative record of performance from which emerges a clear picture of what students know, can do and how they have progressed over the period.

III. Multiple Assessment

These include a range of activities like quizzes, worksheets, oral presentations, class discussions, etc.

IV. Periodic Pen and Paper Assessment

Prescribed Textbook- Kaveri: Textbook of English for Grade 9

The textbook has been developed based on common curricular goals rather than rigid differentiation between R1 & R2. The textbook content, learning outcomes, and assessment remain aligned with the common competency framework envisaged for R1 and R2 at the secondary stage, and therefore, the same textbooks can be transacted flexibly in accordance with the learner profile and institutional context.

Question Paper Design- R1 & R2

ENGLISH LANGUAGE – SYLLABUS CLASS – IX (2026-27) R1

SUBJECT CODE –

Section		Weightage
A	Reading Skills	20 Marks
B	Writing Skills and Grammar	30 Marks
C	Language through Literature	30 Marks
D	Internal Assessment	20 Marks

Section A – Reading Skills

I. Reading Comprehension through Unseen Passage – 20 Marks (10+10)

- Descriptive/ Discursive Passage – 400-450 words – 10 Marks
- Case Based Passage (With verbal/visual inputs – statistical data/chart etc.) – 200-250 words – 10 Marks

Total Length of the two passages to be 600-700 words.

Question types to be included: Selected and constructed responses (MCQ's, Objective type, VSAQs, SAQs)

Section B – Writing Skills and Grammar – 30 Marks (10+20)

II. Grammar – 10 Marks (04+03+03)

- Sequence of Tenses in different contexts of communication
 - Modal Auxiliaries and their functions in expressing ability, obligation, permission, possibility and advice
 - Reported Speech in extended texts including
 - statements
 - questions
 - commands and requests
 - Conditional Clause – Type 1
 - Subject–Verb Concord
 - Determiners
 - Clauses – Noun Clause, Relative Clause
3. Editing/Omitting (Selected responses – MCQs) – 04 Marks
 4. Sentence Rearrangement – 03 Marks
 5. Sentence Transformation – 03 Marks

III. Writing Skills – 20 Marks (03+05+05+07)

6. Writing a Notice, Informal Invitation (Word Limit – Up to 50 words) – 3 Marks
7. Writing a Letter to Editor, Formal E-mail on a given issue for presenting views and suggestions –(Word Limit – 120-150 words) – 5 Marks
8. Writing a Factual Description, Magazine Article (Word Limit – 120-150 words) – 5 Marks
9. Writing Descriptive, Narrative Essay (Word Limit – 200-250 words) – 7 Marks

For questions 6 to 9 attempt any one as per the internal choice provided. The internal choice could comprise both same or different topics.

Section C – Language through Literature – 30 Marks (10 + 10 + 05 + 05)

IV. Extract Based Questions – 5x2 = 10 Marks

10. One extract out of two, from Drama / Prose.
11. One extract out of two, from poetry.

Types of questions to be included – Selected and constructed responses (MCQs, Objective Type Questions, VSAQs)

V. Constructed Responses (Short & Long Answer Questions)

12. Five out of Six Questions to be answered in 40-50 words. 5x2 = 10 Marks

13. One out of two Questions assessing extrapolation beyond the text and across the texts to be answered in about 120-150 words. 5 Marks
14. One out of two Questions assessing theme / plot/ character to be answered in about 120-150 words. 5 Marks

INTERNAL ASSESSMENT 20 MARKS	
Periodic Pen and Paper Tests	05 Marks
Multiple Assessment (Quizzes/ Oral Discussions/Presentations etc.)	05 marks
Portfolio	05 Marks
Subject Enrichment projects (ALS/ Art / IKS / Tech Integrated)	05 Marks

ENGLISH LANGUAGE – SYLLABUS CLASS – IX (2026-27) R2**SUBJECT CODE –**

Section		Weightage
A	Reading Skills	20 Marks
B	Writing Skills and Grammar	30 Marks
C	Language through Literature	30 Marks
D	Internal Assessment	20 Marks

Section A – Reading Skills**I. Reading Comprehension through Unseen Passage – 20 Marks (12 + 8)**

- Factual/ Literary Passage – 400-450 Words – 12 Marks
- Case Based Passage (With verbal inputs) – 200-250 Words – 8 Marks

Total Length of the two passages to be 600-700 words.

(Question types to be included: Selected and constructed responses (MCQ's, Objective type, VSAQs, SAQs)

Section B – Writing Skills and Grammar – 30 Marks (10+20)**II. Grammar – 10 Marks (04+03+03)**

- Sequence of Tenses in different contexts of communication
 - Modal Auxiliaries and their functions in expressing ability, obligation, permission, possibility and advice
 - Reported Speech in extended texts including
 - statements
 - questions
 - commands and requests
 - Conditional Clause – Type 1
 - Subject–Verb Concord
 - Determiners
 - Clauses – Noun Clause, Relative Clause
3. Paragraph Completion (Selected responses: Fill ups with options) – 04 Marks
 4. Sentence Rearrangement – 03 Marks
 5. Sentence Transformation – 03 Marks

III. Writing Skills – 20 Marks (04+05+05+06)

6. Writing a Notice, Creating a Poster (Word Limit – Up to 50 words) – 4 Marks
7. Writing a Letter to the Editor, Formal E-mail on a given issue for presenting views and suggestions (Word Limit – 120-150 words) – 5 Marks
8. Writing a Speech, Magazine Article based on visual or verbal cues (Word Limit – 120-150 words) -5 Marks
9. Writing a Narrative Essay (Word Limit – 150-180 words) – 6 Marks

For questions 6 to 9 attempt any one as per the internal choice provided. The internal choice could comprise both same or different topics.

Section C – Language through Literature – 30 Marks (15 + 10 + 05)

IV. Extract-Based Questions – 5x3 = 15 Marks

10. One extract out of two, from Prose.
11. One extract out of two, from Drama.
12. One extract out of two, from Poetry.

Types of questions to be included – Selected and constructed responses (MCQs, Objective type questions, VSAQs)

V. Constructed Responses (Short & Long Answer Questions)

13. Five out of Seven Questions to be answered in 40-50 words 5x2 = 10 Marks
14. One out of two Questions to be answered in 120-150 words to assess extrapolation beyond the text and across the texts; theme / plot/ character. 5 Marks

INTERNAL ASSESSMENT 20 MARKS	
Periodic 'Pen and Paper Tests	05 Marks
Multiple Assessment (Quizzes/ Oral Discussions/Presentations etc.)	05 marks
Portfolio	05 Marks
Subject Enrichment projects (ALS/ Art / IKS / Tech Integrated)	05 Marks

Mathematics

Class IX (2026 – 27)

Introduction:

The Mathematics curriculum for the Secondary stage has been redesigned in alignment with the National Education Policy 2020 and the National Curriculum Framework for School Education (NCF – SE) 2023, prioritizing deep conceptual understanding and logical reasoning. The revised syllabus places strong emphasis on developing core mathematical competencies, including problem-solving, visualisation, mathematical modelling, mathematical communication, computational thinking, and data analytics. The syllabus integrate Indian Knowledge System with contemporary mathematical knowledge, highlighting the rich contributions of Indian mathematicians to foster a sense of pride and historical context. A deliberate shift from rote learning to competency-based education ensures that students build deep conceptual understanding and logical reasoning rather than mere procedural fluency. Greater emphasis has been laid on the integration of real-life applications and experiential learning, encouraging students to connect mathematical concepts with everyday situations and cross-disciplinary contexts. Greater emphasis has been laid on competency based learning outcomes encouraging students to connect mathematical concepts with everyday situations and inter-disciplinary contexts. Continuous and holistic assessment through projects, activities, and investigations forms an integral part of the learning process, moving beyond summative examinations.

At the secondary stage, the curriculum focuses on developing essential global mathematical competencies, including mathematical representation through quantities and relations, mathematical modelling and algorithm building, and effective mathematical communication. The study of the number system, algebra, geometry, mensuration, statistics and probability is designed to build a strong foundation for higher education while enhancing functional life skills. The curriculum thus aims to build rich mathematical learning frameworks not only for higher academic pursuits but also for the practical demands of life in a rapidly changing, data-driven world.

Objectives: The broad objectives of teaching Mathematics at the secondary stage are to help the learners to:

- develop logical thinking, critical reasoning, and a structured approach to problem-solving;
- build the ability to recognise, analyse, and solve diverse problems with confidence and adaptability;
- communicate mathematical ideas effectively using appropriate language, symbols, and representations;
- appreciate the beauty, history, and real-life relevance of Mathematics as a discipline;
- connect mathematical concepts to fields such as Science, Technology, Engineering, and Economics;
- engage in both collaborative and independent mathematical exploration and learning;
- develop habits of precision, accuracy, and logical consistency in mathematical work;
- build confidence to explore, experiment, and grow in mathematical understanding without fear of failure.

Curricular Goals (CGs) and Competencies (Cs) from the NCF-SE 2023

CG-1: Understands numbers (natural, whole, integer, rational, irrational, and real), ways of representing numbers, relationships amongst numbers, and number sets.

C-1.1 Develops understanding of numbers, including the set of real numbers and its properties.

CG-2: Builds deductive and inductive logic to prove theorems related to numbers and their relationships (such as '2 is an irrational number', a recursion relation for *Virahanka* numbers, a formula for the sum of the first n square numbers).

C-2.1 Understanding of powers (radical powers) and exponents.

CG-3: Discovers and proves algebraic identities and models real-life situations in the form of equations to solve them.

C-3.1 States and proves remainder theorem, factor theorem, and division algorithm.

C-3.2 Models and solves contextualised problems using equations (for example, simultaneous linear equations in two variables or single polynomial equations), and draws conclusions about a situation being modelled.

C-3.3 Learns Brahmagupta's quadratic formula (in both symbolic and poetic form) and its derivation, and uses it to solve some of the poetic puzzles of Bhaskara as well as modern-day problems.

CG-4: Analyses characteristics and properties of two-dimensional geometric shapes, and develops mathematical arguments to explain geometric relationships.

C-4.1 Describes relationships including congruence of two-dimensional geometric shapes (such as lines, angles, triangles) to make and test conjectures and solve problems.

C-4.2 Proves theorems using Euclid's axioms and postulates for triangles and quadrilaterals, and applies them to solve geometric problems.

C-4.3 Proves theorems about the geometry of a circle, including its chords, subtended angles, inscribed polygons, and area in terms of pi.

C-4.4 Understands the irrationality of pi, the best approximations to be discovered over human history, and the first exact formula (infinite series) for pi given by Madhava.

C-4.5 Specifies locations and describes spatial relationships using coordinate geometry, for example, plotting a pair of linear equations and graphically finding the solution, or finding the area of triangle with given coordinates as vertices.

C-4.6 Understands the definitions of the basic trigonometric functions, their history and motivation (including the introduction of the sin and cos functions by Aryabhata using chords), and their utility across the sciences.

CG-5: Derives and uses formulae to calculate areas of plane figures, surface area, and volumes of solid objects.

C-5.1 Visualises, represents, and calculates the area of a triangle using Heron's formula and its generalisation to cyclic quadrilaterals given by Brahmagupta's formula.

C-5.2 Visualises and uses mathematical thinking to discover formulae to calculate surface areas and volumes of solid objects (cubes, cuboids, spheres, hemispheres, right circular cylinders or cones, and their combinations).

CG-6: Analyses and interprets data using statistical concepts (such as measures of central tendency, standard deviations) and probability.

C-6.1 Applies measures of central tendencies, such as mean, median, and mode.

C-6.2 Applies concepts from probability to solve problems on the likelihood of everyday events.

CG-7: Begins to perceive and appreciate the axiomatic and deductive structure of Mathematics.

C-7.1 Proves mathematical statements and carries out geometric constructions using stated assumptions, axioms, postulates, definitions, and mathematics vocabulary.

C-7.2 Visualises and appreciates geometric proofs for algebraic identities and other 'proofs without words'.

C-7.3 Proves theorems using Euclid's axioms and postulates for angles, triangles, quadrilaterals, circles, area-related theorems for triangles, and parallelograms.

C-7.4 Constructs different geometrical shapes like bisectors of line segments, angles and their bisectors, triangles, and other polygons, satisfying given constraints.

CG-8: Builds skills, such as visualisation, optimisation, representation, and mathematical modelling along with their application in daily life.

C-8.1 Models daily-life phenomena and uses representations, such as graphs, tables, and equations to draw conclusions.

C-8.2 Uses two-dimensional representations of three-dimensional objects to visualise and solve problems, such as those involving surface area and volume.

C-8.3 Employs optimisation strategies to maximise desired quantities (such as area, volume, or other output) under given constraints.

CG-9: Develops computational thinking, i.e., deals with complex problems and is able to break them down into a series of simple problems that can then be solved by suitable procedures/algorithms.

C-9.1 Decomposes a problem into sub-problems.

C-9.2 Describes and analyses a sequence of instructions being followed.

C-9.3 Analyses similarities and differences among problems to make one solution or procedure work for multiple problems.

C-9.4 Engages in algorithmic problem-solving to design such solutions.

CG-10: Knows and appreciates important contributions of mathematicians from India and around the world.

C-10.1 Recognises the important contributions made by mathematicians (Indian and others) in the field of Mathematics (such as the evolution of numbers, geometry, and algebra).

C-10.2 Recognises modern contributions to Mathematics made in both India and abroad, and understands the next frontiers and next major open questions in the field of Mathematics.

CG-11: Explores connections of Mathematics with other subjects.

C-11.1 Applies mathematical knowledge and tools to analyse problems or situations in multiple subjects across Science, Social Science, Visual Arts, Music, Vocational Education, and Sports.

COURSE STRUCTURE CLASS – IX

Units	Unit Name	Chapter Name	Marks
I	Number System	<ul style="list-style-type: none"> Number System 	07
II	Algebra	<ul style="list-style-type: none"> Introduction to Polynomials Sequences and Progressions Exploring Algebraic Identities Linear Equations in Two Variables 	20
III	Coordinate Geometry	<ul style="list-style-type: none"> Coordinate Geometry 	04
IV	Geometry	<ul style="list-style-type: none"> Introduction to Euclid's Geometry: Axioms and Postulates Lines and Angles Triangles – Congruence Theorems 4-gons (Quadrilaterals) Circles 	25
V	Mensuration	<ul style="list-style-type: none"> Area and Perimeter Surface Area and Volume 	14
VI	Statistics and Probability	<ul style="list-style-type: none"> Statistics Introduction to Probability 	10
	Total		80

Chapter Name	Key Concepts	Relevant CGs	Competencies
	Unit 1: Number System		No. of periods : 12
Number System	<ul style="list-style-type: none"> Introduction to rational numbers Representation of rational numbers on the number line Density of rational numbers and its proof Finding rational numbers between any two rational numbers Decimal representation of rational numbers Introduction to irrational numbers Proof of irrationality of $\sqrt{2}$ and $\sqrt{3}$ The square root spiral 	CG-1, C-1.1, CG-9	The student will be able to: <ul style="list-style-type: none"> Understand the concept of a rational number. Represent rational numbers on the number line. Understand the properties of rational numbers. Explain the concept of density of rational numbers. Compute decimal representation of rational numbers. Understand the concept of irrational numbers. Prove the irrationality. Construct the square root spiral. Apply computational thinking to represent rational and irrational

			numbers through algorithms and visual models, generate decimal expansions systematically, and reason about numbers using step-by-step logical procedures.
	UNIT II: ALGEBRA		No. of periods : 66
Introduction to Polynomials	<ul style="list-style-type: none"> Algebraic expressions Definition of a polynomial. Degree of a polynomial Introduction to linear polynomials and applications Exploring linear patterns Modelling linear growth and linear decay Linear relationships Visualising linear relationships Slope and y-intercept of a line $y = ax + b$ 	CG-3, C-3.2, CG-9	<p>The student will be able to:</p> <ul style="list-style-type: none"> Understand the meaning of an algebraic expression. Define a polynomial. Identify the degree, terms and coefficients of terms in a polynomial. Model linear growth and decay using linear polynomials. Explain and identify patterns in linear relationships. Identify the slope and y-intercept of a linear equation in two variables. Graph a linear equation in two variables. Use computational thinking to identify patterns, construct linear expressions, and systematically represent and analyse linear relationships using equations and graphs.
Sequences and Progressions	<ul style="list-style-type: none"> Introduction to sequences Explicit or general rule of a sequence Recursive rule of a sequence Arithmetic Progressions (AP): nth term, visualising an AP, and practical contexts leading to Aps Sum of the first n natural numbers Geometric Progressions (GP): nth term, visualising a GP, and practical contexts leading to GPs Applications of GP in fractals Tower of Hanoi puzzle 	CG-11, C-8.1, CG-9	<p>The student will be able to:</p> <ul style="list-style-type: none"> Understand the concept of a sequence of numbers. Identify the pattern in a sequence and predict the next few terms. Determine the recursive and explicit rules for different sequences. Obtain the terms of sequence given its recursive and explicit rule. Identify Arithmetic Progressions (AP). Determine the nth term of an AP. Visualise an AP graphically. Identify Geometric Progressions (GP). Determine the nth term of a GP. Visualise a GP graphically. Analyse attributes of fractals using GP. Solve the Tower of Hanoi puzzle. Use computational thinking to identify patterns, write step-by-step rules, and model patterns in sequences and progressions.

<p>Exploring Algebraic Identities</p>	<ul style="list-style-type: none"> • Revisiting algebraic identities • Visualising identities using geometrical models • Factorisation of algebraic expressions using identities • More identities and their applications • Visualising factorisation of quadratic expressions through algebra tiles and without using algebra tiles • Finding new identities • Simplifying rational expressions 	<p>CG-7, C-7.2, CG-9</p>	<p>The student will be able to:</p> <ul style="list-style-type: none"> • Visualise algebraic identities using geometric models. • Determine the factors of algebraic expressions using identities. • Interpret factors of quadratic expressions through geometric models. • Find simplified versions of rational expressions. • Use computational thinking strategies, such as decomposition and step-by-step procedures to visualise algebraic identities, factor expressions, and simplify rational expressions.
<p>Linear Equations in Two Variables</p>	<ul style="list-style-type: none"> • Introduction to linear equations in two variables through practical examples • Solution of linear equation in two variables: graphical representation • Slope-intercept form of linear equation in two variables • Drawing graphs of linear equations when x and y assume only certain values • Pair of linear equations in two variables • Graphical method for solving a pair of linear equations in two variables • Nature of solutions: consistency and inconsistency • Algebraic methods of solving a pair of linear equations: substitution and elimination method 	<p>CG-3, C-3.2, C-8.1, CG-9</p>	<p>The student will be able to:</p> <ul style="list-style-type: none"> • Understand the concept of a linear equation in two variables. • Graph a pair of linear equations. • Solve a pair of linear equations graphically. • Solve a pair of linear equations through the methods of substitution and elimination. • Determine the nature of solutions of a pair of linear equations. • Model and solve contextualised problems using a pair of linear equations and draw conclusions. • Model daily-life phenomena using representations, such as graphs, tables, and equations. • Use computational thinking to systematically represent, solve, and interpret pairs of linear equations through graphs, tables, and step-by-step procedures.

		UNIT III: COORDINATE GEOMETRY	No. of periods : 6
Coordinate Geometry	<ul style="list-style-type: none"> • Brief history of coordinate geometry • The 2-D Cartesian coordinate system • Distance between two points in the 2-D plane • Midpoint of the line-segment between two points in the 2-D plane 	CG-4, C-4.5, CG-9	<p>The student will be able to:</p> <ul style="list-style-type: none"> • Specify locations and the position of one point relative to another point using coordinates. • Represent a floor plan on a grid using coordinates. • Compute the distance between two points using coordinates. • Determine whether three points lie in a straight line using coordinates. • Compute the position of the midpoint of a line segment using coordinates. • Check whether a triangle is right-angled using coordinates. • Apply computational thinking to model situations on the coordinate plane and verify geometric properties through systematic reasoning.
		UNIT IV: GEOMETRY	No. of periods : 69
Introduction to Euclid's Geometry: Axioms and Postulates	<ul style="list-style-type: none"> • History of geometry • Constructing a square with a given side as described in the Baudhayana's Sulbasutras • Discovering Euclid's definitions • Axioms: Axioms of measurement and rules for geometric objects 	CG-7, C-7.1, C-7.3	<p>The student will be able to:</p> <ul style="list-style-type: none"> • Describe how geometry grew from the practical needs ancient civilisations. • Describe contributions of India, Egypt and Greece to the development of geometric ideas. • Understand the role of definitions, axioms, and postulates. • Explain that there are elements of plane geometry (point, line, surface) for which we have an intuitive sense. • State the 5 postulates of Euclidean geometry. • Define parallelism of straight lines. • Explain the construction of a square as given in the Sulbasutras. • Justify simple constructions using the axioms.
Lines and Angles	<ul style="list-style-type: none"> • Rays and angles • Measures of angles • Intersecting lines and angles • Pairs of angles • Theorems and examples on intersecting lines • Theorems and examples on parallel lines 	CG-7, C-7.1, C-7.3, CG-9	<p>The student will be able to:</p> <ul style="list-style-type: none"> • Explain the notion of an angle. • Explain the notion of a ray. • Explain that angles are formed between two rays with a common starting point. • State that a straight angle equals two right angles and measures 180° while a right angle measures 90°.

			<ul style="list-style-type: none"> • Classify angles as acute, right, obtuse, or reflex. • Define parallelism. • State and apply the linear pair theorem and its converse. • Follow proof by contradiction in geometry. • Prove that vertically opposite angles are equal. • Identify corresponding, alternate, and interior angles. • Explain transitivity of parallelism. • Explain why a triangle must have at least two acute angles; why it cannot have two obtuse angles, or all three angles less than 60° • Apply computational thinking to analyse geometric ideas by breaking constructions into ordered steps, using axioms and postulates as rules, and justifying geometric results through logical step-by-step reasoning.
<p>Triangles: Congruence Theorems</p>	<ul style="list-style-type: none"> • Practical applications of triangles • Proofs of conditions of congruence of triangles • Theorems on triangles • Propositions and their converse • Problems based on applications of theorems on triangles 	<p>CG-4, C 4.1, C-7.3</p>	<p>The student will be able to:</p> <ul style="list-style-type: none"> • Explain that a triangle is rigid, unlike a quadrilateral. • Identify uses of triangle rigidity. • Explain why triangles give strength and stability to structures. • Describe what it means for two triangles to be congruent. • Identify correspondence between the vertices, sides, and angles of two congruent triangles. • Use the SAS congruence axiom. • Use the SSS congruence condition. • Use the ASA congruence condition. • Use the RHS congruence condition. • Use the AAS congruence condition. • Prove the basic properties of isosceles triangles. • Explain the notion of a proposition. • Explain the notion of converse of a proposition. • Identify the converse of a given proposition. • Explain that not all converses are true; use counter examples to show that some converses are false. • Explain why SSA is not, in general, a valid congruence condition.

			<ul style="list-style-type: none"> • Identify the situations where SSA is a valid congruence condition. • Justify the role of diagram accuracy.
4-gons (Quadrilaterals)	<ul style="list-style-type: none"> • Properties of parallelograms • Important theorems related to parallelograms and their proof • Midpoint theorem and its applications • Understanding the notion of central symmetry in the context of parallelograms 	CG-4, C-4.2, C-7.3	<p>The student will be able to:</p> <ul style="list-style-type: none"> • Frame a precise definition of a 4-gon. • Prove various characterisations of a parallelogram. • Prove the midpoint theorem. • Prove a converse of the midpoint theorem. • Prove that the medians of a triangle are concurrent and each median is divided in the ratio 2:1 at the point of concurrence. • Prove that the 4-gon formed by joining the midpoints of a given 4-gon is a parallelogram. • Find the coordinates of the midpoint of a line segment given its end points and find the coordinates of the fourth vertex of a parallelogram given the other three. • Understand reflection and rotation symmetries of 4-gons. • Understand how any 4-gon can tile a plane. • Practice forming logical converses of statements and asking questions guided by converses of theorems. • Engage in drawing, measurement and paper manipulation activities to discover geometric patterns involving triangles and 4-gons.
Circles	<ul style="list-style-type: none"> • Practical applications and uses of circles • Definitions related to a circle — centre, diameter, and radius • Chords and the angles they subtend • Midpoints and perpendicular bisectors of chords • Distance of chords from the centre • Subtended angles by an arc • Cyclicity of points 	CG-4, C-7.3, CG-9	<p>The student will be able to:</p> <ul style="list-style-type: none"> • State the definition of a circle. • Explain the meanings of the terms 'chord', 'diameter', 'radius', 'arc', 'segment', and 'sector'. • Explain why there exists a unique circle through three non-collinear points. • Construct the circumcircle and circumcentre of a triangle. • Describe the location of the circumcentre for acute, obtuse, and right-angled triangles. • Explain what 'angle subtended by an arc at the centre' means. • Explain why 'equal chords subtend equal angles at the centre'.

			<ul style="list-style-type: none"> • Explain why ‘chords that subtend equal angles at the centre are equal’. • Explain why ‘the line from the centre of a circle to the midpoint of a chord is perpendicular to the chord’. • Explain why ‘a perpendicular from the centre to a chord bisects the chord’. • State the relationship between length of a chord and its distance from the centre of the circle. • Explain why ‘equal chords are equidistant from the centre (and conversely)’. • Explain why ‘among unequal chords, the longer chord is closer to the centre’. • Explain why ‘the diameter is the longest chord’. • Explain why ‘the angle subtended by an arc at the centre is double the angle subtended by the arc at any point on the remaining part of the circle’. • Explain why ‘angles in the same segment of a circle are equal’. • Explain why ‘the angle in a semicircle is a right angle’. • Determine when four given points are concyclic. • Explain why ‘a quadrilateral with supplementary opposite angles is cyclic, and conversely’. • Explain how circular wheels have influenced transport, farming, building, and technology. • Identify cultural motifs involving circles, for example, the Dharmachakra, Ashoka Chakra, Sudarshan Chakra. • Use computational thinking to break down circle-related problems, apply geometric rules step-by-step, and verify properties of figures, such as chords, angles, and cyclic quadrilaterals through systematic reasoning.
	UNIT V: MENSURATION		No. of periods : 27
Mensuration : Area and Perimeter	<ul style="list-style-type: none"> • Perimeter of shapes • Perimeter of a circle: Introduction to Pi and its irrationality • Length of an arc 	CG-5, C-5.1, CG-9	<p>The student will be able to:</p> <ul style="list-style-type: none"> • Define perimeter as the length around the boundary of any shape. • Explain that the circumference-to-diameter ratio is constant for all circles.

	<ul style="list-style-type: none"> • Area of shapes: rectangles, parallelograms, and triangles • Heron's formula • Squaring a rectangle: Proof from Baudhayana's Sulbasutras • Area of a circle: derivation • Area of the sector of a circle • Brahmagupta's formula for area of a cyclic 4-gon • Heron's formula as a special case of Brahmagupta's formula 		<ul style="list-style-type: none"> • List historical approximations to π (from Archimedes, Aryabhata, and Zu Chongzhi). • Compute the circumference of a circle and the length of an arc. • Apply ideas of circle perimeter and arc-length to real-world contexts. • Explain why a median of a triangle divides it into two triangles of equal area. • Use Heron's formula to compute the area of a triangle from its sides. • Explain the classical problem of 'squaring' a given shape. • Explain how ancient civilisations approximated the area of a circle. • Compute the area of a circle using the formula. • Explain and use the formula for area of a sector of a circle. • Solve problems on areas of sectors and segments of circles. • State Brahmagupta's formula for the area of a cyclic quadrilateral in terms of its sides. • Explain why Heron's formula is a 'special case' of Brahmagupta's formula. • Explain the notion of 'special case' and 'generalisation' in mathematics. • Use computational thinking to break down shapes, apply step-by-step methods to calculate perimeter and area, recognise patterns across formulae, and understand generalisation and special cases in geometry.
<p>Mensuration : Surface Area and Volume</p>	<ul style="list-style-type: none"> • Surface areas and volumes of spheres (including hemispheres) and right circular cones 	<p>CG-5, C-5.1, CG-9</p>	<p>The student will be able to:</p> <ul style="list-style-type: none"> • Recognise cuboids and cubes in real-life situations. • Compute the surface area and volume of a cuboid. • Explain how a cube is a 'special case' of a cuboid. • Describe a right circular cylinder using its radius and height. • Compute the surface area and volume of a cylinder. • Recognise cones in daily life, and describe them using radius and height.

			<ul style="list-style-type: none"> • Compute the surface area and volume of a cone. • Recognise a pyramid, and identify its base and apex. • Compute the surface area and volume of a pyramid. • Recognise spheres in real-life situations. • Compute the surface area and volume of a sphere. • Use computational thinking to systematically calculate, and compare surface areas and volumes of 3-D shapes by varying dimensions and analysing patterns.
	UNIT VI: STATISTICS AND PROBABILITY		No. of periods : 24
Statistics	<ul style="list-style-type: none"> • Graphical representation of data • Measures of central tendency 	CG-6, C-6.1, CG-9	<p>The student will be able to:</p> <ul style="list-style-type: none"> • Collect, organise, visualise and interpret data to answer a statistical investigative question. • Compute and apply weighted average in different settings. • Read and interpret stacked bar graphs and 100% stacked bar graphs. • Apply computational thinking strategies to analyse real-life data, create appropriate graphical representations, and interpret mean, median and mode for decision-making.
Introduction to Probability	<ul style="list-style-type: none"> • Concept of probability and randomness • The probability scale • Empirical probability: analysing statistical data and performing experiments • Theoretical probability: sample space and events • Representing probability through tree diagrams and tables 	CG-6, C-6.2, CG-9	<p>The student will be able to:</p> <ul style="list-style-type: none"> • Understand the concept of randomness. • Describe the likelihood of an event using the probability scale. • Estimate the empirical probability of the occurrence of an event by analysing statistical data. • Define theoretical probability of an event. • Apply the definition of theoretical probability to compute the probability of an event. • Compute probability of events with the help of tree diagrams and tables. • Use computational thinking strategies, such as pattern recognition and simulation, to model random experiments and estimate probabilities.

MATHEMATICS QUESTION PAPER DESIGN
CLASS – IX (2026-27)

Time: 3 Hrs.

Max. Marks: 80

S. No.	Typology of Questions	Total Marks	% Weightage (approx.)
1	<p>Remembering: Exhibit memory of previously learned material by recalling facts, terms, basic concepts, and answers.</p> <p>Understanding: Demonstrate understanding of facts and ideas by organizing, comparing, translating, interpreting, giving descriptions, and stating main ideas</p>	43	54
2	<p>Applying: Solve problems to new situations by applying acquired knowledge, facts, techniques and rules in a different way.</p>	19	24
3	<p>Analysing: Examine and break information into parts by identifying motives or causes. Make inferences and find evidence to support generalizations</p> <p>Evaluating: Present and defend opinions by making judgments about information, validity of ideas, or quality of work based on a set of criteria.</p> <p>Creating: Compile information together in a different way by combining elements in a new pattern or proposing alternative solutions</p>	18	22
Total		80	100

INTERNAL ASSESSMENT	20 MARKS
Pen Paper Test and Multiple Assessment (5+5)	10 Marks
Portfolio	05 Marks
Lab Practical (Lab activities to be done from the prescribed books)	05 Marks

Prescribed Books:

1. Mathematics - Textbook for class IX - NCERT Publication
2. Guidelines for Mathematics Laboratory in Schools, class IX - CBSE Publication
3. Laboratory Manual - Mathematics, secondary stage - NCERT Publication
4. Mathematics exemplar problems for class IX, NCERT publication

हिंदी पाठ्यक्रम (2026-27)

कक्षा-नवीं (आर -1)

भाषा किसी भी ज्ञान-क्षेत्र की आधारशिला है। हम प्रकृति और समाज को बहुत हद तक अपनी भाषा के ढाँचे के माध्यम से ही समझते और विश्लेषित करते हैं। इस कार्य को करने में भाषा का साहित्य हमारी विशेष सहायता करता है। माध्यमिक स्तर पर प्रवेश करने वाले विद्यार्थी सामान्य भाषा-ज्ञान से विशिष्ट अनुशासनात्मक अध्ययन की ओर बढ़ते हैं।

राष्ट्रीय शिक्षा नीति 2020 और विद्यालयी शिक्षा हेतु राष्ट्रीय पाठ्यचर्या की रूपरेखा 2023 की दृष्टि के अनुरूप यह पाठ्यक्रम हिंदी को केवल एक विषय नहीं बल्कि अनुभवों, मूल्यों, बहुसांस्कृतिकता, सृजनात्मकता और संवाद की एक समृद्ध प्रक्रिया के रूप में प्रस्तुत करता है। यह ज्ञान के संग्रह तक सीमित नहीं रहता बल्कि विद्यार्थियों को सोचने, कल्पना करने, विश्लेषण करने और अभिव्यक्ति के लिए प्रेरित करता है। पाठ्यक्रम का लक्ष्य विद्यार्थियों की चेतना को इस दिशा की ओर ले जाना है कि हिंदी भाषा के माध्यम से यथार्थ को अर्थात् जो भी घटित हो रहा है, उसे समझा जाए और उसमें अपनी आकांक्षाओं का चित्र रचा जाए। इस पाठ्यक्रम का केंद्रीय उद्देश्य पाठों का पठन-पाठन मात्र नहीं बल्कि उनके माध्यम से विद्यार्थियों में गहन पाठानुभूति, संवेदनशील अभिव्यक्ति, तार्किक विश्लेषण, संदर्भ-आधारित लेखन तथा भाषिक एवं सांस्कृतिक विविधता की समझ को विकसित करना है। हिंदी भाषा के सीखने-सिखाने के माध्यम से विद्यार्थियों में भाषा, संस्कृति का समावेशी दृष्टिकोण पैदा करना, जीवन के विविध संदर्भों को समझना, विविधता के प्रति सकारात्मकता का बोध पैदा करना- यह सब आवश्यक रूप से अपेक्षित है।

नवीं कक्षा में प्रवेश करने वाले विद्यार्थी की भाषा-शैली और विचार-बोध का एक ऐसा आधार बन चुका होता है कि अब उसे उसके भाषिक दायरे के विस्तार और वैचारिक समृद्धि के लिए आवश्यक संसाधन मुहैया कराए जाने की आवश्यकता होती है। माध्यमिक स्तर तक आते-आते विद्यार्थी किशोरावस्था में प्रवेश कर चुके होते हैं और उनमें सुनने, बोलने, पढ़ने, लिखने एवं समझने के साथ-साथ आलोचनात्मक दृष्टि विकसित होने लगती है। उनमें भाषा के सौंदर्यात्मक पक्ष, कथात्मकता, गीतात्मकता, समाचार-पत्रों की समझ, शब्द-शक्तियों के बीच अंतर की समझ, राजनैतिक चेतना एवं सामाजिक चेतना का विकास हो जाता है। वे आस-पड़ोस की भाषा और आवश्यकता के अनुसार उपयुक्त भाषा-प्रयोग, शब्दों के सुविचारित प्रयोग, भाषा की नियमबद्ध प्रकृति आदि से परिचित हो जाते हैं। इतना ही नहीं, वे विभिन्न विधाओं और अभिव्यक्ति की अनेक शैलियों से भी परिचित हो चुके होते हैं। अब विद्यार्थियों का अध्ययन आस-पड़ोस, राज्य-देश की सीमा को लाँघते हुए वैश्विक क्षितिज तक फैल जाता है। इन विद्यार्थियों की दुनिया में समाचार, खेल, फिल्म तथा अन्य कलाओं के साथ-साथ पत्र-पत्रिकाएँ और अलग-अलग तरह की पुस्तकें भी प्रवेश पा चुकी होती हैं।

एनसीईआरटी के पाठ्यक्रम और पाठ्यपुस्तकों में आर1 और आर2 के संदर्भ एनसीसीएफ-एसई 2023 के परिप्रेक्ष्य पर आधारित सांकेतिक और प्रासंगिक हैं। इन संदर्भों का उद्देश्य माध्यमिक स्तर पर आर1 और आर2 के बीच किसी भी प्रकार का संरचनात्मक या योग्यता-आधारित अंतर दर्शाना नहीं है।

पाठ्यपुस्तक की विषयवस्तु, अधिगम परिणाम और मूल्यांकन माध्यमिक स्तर पर आर 1 और आर 2 के लिए परिकल्पित सामान्य योग्यता ढाँचे के अनुरूप हैं, इसलिए संदर्भ के अनुसार इन पाठ्यपुस्तकों का लचीले ढंग से उपयोग किया जा सकता है।

इस स्तर पर हिंदी का अध्ययन-अध्यापन साहित्यिक, सांस्कृतिक और व्यावहारिक भाषा के रूप में कुछ इस तरह से हो कि माध्यमिक स्तर तक पहुँचते-पहुँचते यह विद्यार्थियों की पहचान, आत्मविश्वास और विमर्श की भाषा बन सके। आवश्यकता इस बात की है कि विद्यार्थी भाषा के लिखित प्रयोग के साथ-साथ सहज और स्वाभाविक मौखिक अभिव्यक्ति में भी सक्षम हो सकें। वे हिंदी की प्रकृति के अनुसार वर्तनी और उच्चारण के आपसी संबंधों को समझ सकें ताकि उनकी लिखित और मौखिक भाषा में समानता एवं स्पष्टता हो।

CG-1: लेखन के विभिन्न रूपों (निबंध, पत्र, लेख, चर्चा, साक्षात्कार, सार्वजनिक भाषण) और नव मीडिया (ईमेल, श्रव्य और दृश्य सामग्री) के माध्यम से प्रभावी संप्रेषण के लिए भाषा का उपयोग करना।

दक्षताएँ	सीखने के संकेत बिंदु/गतिविधियाँ
C-3.1-विभिन्न श्रव्य और लिखित सामग्री का विश्लेषण और मूल्यांकन करना।	<ul style="list-style-type: none"> विभिन्न प्रकार की श्रव्य और लिखित सामग्री में विवरणों का अवलोकन और विश्लेषण करके उन्हें व्यवस्थित रूप से लिखते हैं। किसी एक विषय पर विभिन्न स्रोतों से प्राप्त सामग्री का विश्लेषण करके उसकी विश्वसनीयता की जाँच करते हैं।
C-3.2-रचना में परिवेश का सावधानीपूर्वक मूल्यांकन करके उचित तर्कों के साथ चर्चा-परिचर्चा करना।	<ul style="list-style-type: none"> पाठ्यवस्तु को पढ़ते और सुनते समय स्वयं के पूर्वग्रहों को पहचानते हैं और साक्ष्यों का मूल्यांकन करके पाठ्यवस्तु/श्रव्य-सामग्री की विश्वसनीयता का निर्धारण करते हैं।

पाठ्यचर्या CG-4: भारतीय भाषाई विविधता से जुड़ी साहित्यिक और सांस्कृतिक विरासत की सराहना करना।

दक्षताएँ	सीखने के संकेत बिंदु/गतिविधियाँ
C-4.1-पाठ को पढ़ते हुए विभिन्न शैलियों की सामग्री के अवलोकन के माध्यम से भारतीय समाज और साहित्यिक विविधता की बहुभाषी प्रकृति की पहचान करना।	<ul style="list-style-type: none"> भारतीय समाज की बहुभाषी प्रकृति को पहचानने के लिए विभिन्न क्षेत्रीय भाषाओं के चलचित्र और वृत्तचित्र देखते हैं और उनके बारे में अपने विचार साझा करते हैं।
C-4.2-भारतीय भाषाओं की विभिन्न साहित्यिक रचनाओं में निहित संस्कृति एवं विरासत की विविधता और उनके आपसी संबंधों की सराहना करना।	<ul style="list-style-type: none"> पढ़ी गई साहित्यिक रचनाओं को विषयों, पात्रों और परिस्थितियों के आधार पर अपने व्यक्तिगत अनुभवों/जीवन से जोड़ते हैं। विभिन्न भारतीय भाषाओं के साहित्य की विशिष्टता और साहित्य जगत में उनके योगदान की सराहना करते हैं।
C-4.3-हमारी संस्कृति और पहचान के निर्माण में भाषा की भूमिका को समझते हुए अभिव्यक्त करना।	<ul style="list-style-type: none"> भाषा में निहित सांस्कृतिक परंपराओं से प्रभावित कहावतों/पहेलियों/मुहावरों के उदाहरण साझा करते हैं। लिखने और बोलने में सांस्कृतिक परंपराओं से प्रभावित अपनी भाषा की शब्दावली का संदर्भों के अनुसार उपयुक्त उपयोग करते हैं।

हिंदी पाठ्यक्रम - आर -1 (2026 - 27)			
कक्षा - नवीं			
खंड			भारांक
क	अपठित बोध		14
ख	व्यावहारिक व्याकरण		16

ग	पाठ्यपुस्तक		30
घ	रचनात्मक लेखन		20
• भारांक - 80 (वार्षिक परीक्षा) +20 (आंतरिक परीक्षा)			
खंड -क (अपठित बोध)		उपभार	कुल भार
विषयवस्तु			
1	अपठित गद्यांश व काव्यांश पर बोध, चिंतन, विश्लेषण, सराहना आदि पर बहुविकल्पीय, अतिलघूत्तरात्मक एवं लघूत्तरात्मक प्रश्न		14
अ	एक अपठित गद्यांश लगभग 200 शब्दों का इसके आधार पर एक अंकीय तीन बहुविकल्पी प्रश्न (1x3=3) पूछे जाएँगे, अतिलघूत्तरात्मक एवं लघूत्तरात्मक प्रश्न (2x2=4) पूछे जाएँगे	7	
ब	एक अपठित काव्यांश लगभग 80-100 शब्दों का इसके आधार पर एक अंकीय तीन बहुविकल्पी प्रश्न (1x3=3) पूछे जाएँगे, अतिलघूत्तरात्मक एवं लघूत्तरात्मक प्रश्न (2x2=4) पूछे जाएँगे	7	
खंड -ख (व्यावहारिक व्याकरण)			
2	व्याकरण के लिए निर्धारित विषयों पर विषयवस्तु का बोध, भाषिक बिंदु /संरचना आदि पर अतिलघूत्तरात्मक एवं लघूत्तरात्मक प्रश्न (1X16 = 16) कुल 20 प्रश्न पूछे जाएँगे, जिनमें से केवल 16 प्रश्नों के उत्तर देने होंगे		16
	(i) शब्द -निर्माण उपसर्ग - 2 अंक ,प्रत्यय - 2 अंक (5 प्रश्नों में से 4 प्रश्न करने होंगे)	4	
	(ii) संज्ञा, सर्वनाम,विशेषण,क्रिया (5 प्रश्नों में से 4 प्रश्न करने होंगे)	4	
	(iii) अर्थ की दृष्टि से वाक्य-भेद - 4 अंक (5 प्रश्नों में से 4 प्रश्न करने होंगे)	4	

	(iv)	अलंकार - 4 अंक शब्दालंकार : अनुप्रास, यमक, श्लेष (5 प्रश्नों में से 4 प्रश्न करने होंगे)	4	
3		खंड -ग (पाठ्यपुस्तक)		30
4		खंड -घ (रचनात्मक लेखन)		20
		लेखन		
	(i)	विभिन्न विषयों और संदर्भों पर विद्यार्थियों के तर्कसंगत विचार प्रकट करने की क्षमता को परखने के लिए संकेत-बिंदुओं पर आधारित समसामायिक एवं व्यावहारिक जीवन से जुड़े हुए तीन विषयों में से किसी एक विषय पर लगभग 120 शब्दों में अनुच्छेद लेखन ।	5	
	(ii)	अभिव्यक्ति की क्षमता पर केंद्रित अनौपचारिक दो विषयों में से किसी एक विषय पर लगभग 100 शब्दों में पत्र लेखन । (विकल्प सहित)	5	
	(iii)	दिए गए विषय / परिस्थिति के आधार पर लगभग 80 शब्दों में संवाद लेखन । (विकल्प सहित)	5	
	(iv)	दिए गए विषय / शीर्षक के आधार पर लगभग 80 शब्दों में सूचना लेखन । (विकल्प सहित)	5	

राष्ट्रीय शैक्षिक अनुसंधान केंद्र द्वारा राष्ट्रीय पाठ्यचर्या की रूपरेखा 2023 के आधार पर जारी की गई पाठ्यपुस्तक के आधार पर साहित्य से संबंधित अध्ययन किया जाए।

हिंदी पाठ्यक्रम (2026-27)

कक्षा-नवीं (आर -2)

राष्ट्रीय पाठ्यचर्या की रूपरेखा 2023 के अनुरूप द्वितीय भाषा के रूप में हिंदी आर 2 के रूप में पढ़ाई जाएगी। रोचक ढंग से इस भाषा का अध्ययन-अध्यापन पूर्णतः स्तरानुकूल रहेगा जिससे सभी

शिक्षार्थी लाभान्वित हो सकें तथा भारतीय भाषाओं के साथ सुरुचिपूर्ण ढंग से सामंजस्य स्थापित कर सकें ।

एनसीईआरटी द्वारा जारी पाठ्यचर्या के लक्ष्यों एवं दक्षताओं को प्रमुख रूप से ध्यान में रखते हुए शिक्षण बिंदुओं का कार्यान्वयन किया जाएगा।

भाषा किसी भी ज्ञान-क्षेत्र की आधारशिला है। हम प्रकृति और समाज को बहुत हद तक अपनी भाषा के ढाँचे के माध्यम से ही समझते और विश्लेषित करते हैं। इस कार्य को करने में भाषा का साहित्य हमारी विशेष सहायता करता है। माध्यमिक स्तर पर प्रवेश करने वाले विद्यार्थी सामान्य भाषा-ज्ञान से विशिष्ट अनुशासनात्मक अध्ययन की ओर बढ़ते हैं।

राष्ट्रीय शिक्षा नीति 2020 और विद्यालयी शिक्षा हेतु राष्ट्रीय पाठ्यचर्या की रूपरेखा 2023 की दृष्टि के अनुरूप यह पाठ्यक्रम हिंदी को केवल एक विषय नहीं बल्कि अनुभवों, मूल्यों, बहुसांस्कृतिकता, सृजनात्मकता और संवाद की एक समृद्ध प्रक्रिया के रूप में प्रस्तुत करता है। यह ज्ञान के संग्रह तक सीमित नहीं रहता बल्कि विद्यार्थियों को सोचने, कल्पना करने, विश्लेषण करने और अभिव्यक्ति के लिए प्रेरित करता है। पाठ्यक्रम का लक्ष्य विद्यार्थियों की चेतना को इस दिशा की ओर ले जाना है कि हिंदी भाषा के माध्यम से यथार्थ को अर्थात् जो भी घटित हो रहा है, उसे समझा जाए और उसमें अपनी आकांक्षाओं का चित्र रचा जाए। इस पाठ्यक्रम का केंद्रीय उद्देश्य पाठों का पठन-पाठन मात्र नहीं बल्कि उनके माध्यम से विद्यार्थियों में गहन पाठानुभूति, संवेदनशील अभिव्यक्ति, तार्किक विश्लेषण, संदर्भ-आधारित लेखन तथा भाषिक एवं सांस्कृतिक विविधता की समझ को विकसित करना है। हिंदी भाषा के सीखने-सिखाने के माध्यम से विद्यार्थियों में भाषा, संस्कृति का समावेशी दृष्टिकोण पैदा करना, जीवन के विविध संदर्भों को समझना, विविधता के प्रति सकारात्मकता का बोध पैदा करना- यह सब आवश्यक रूप से अपेक्षित है।

नवीं कक्षा में प्रवेश करने वाले विद्यार्थी की भाषा-शैली और विचार-बोध का एक ऐसा आधार बन चुका होता है कि अब उसे उसके भाषिक दायरे के विस्तार और वैचारिक समृद्धि के लिए आवश्यक संसाधन मुहैया कराए जाने की आवश्यकता होती है। माध्यमिक स्तर तक आते-आते विद्यार्थी किशोरावस्था में प्रवेश कर चुके होते हैं और उनमें सुनने, बोलने, पढ़ने, लिखने एवं समझने के साथ-साथ आलोचनात्मक दृष्टि विकसित होने लगती है। उनमें भाषा के सौंदर्यात्मक पक्ष, कथात्मकता, गीतात्मकता, समाचार-पत्रों की समझ, शब्द-शक्तियों के बीच अंतर की समझ, राजनैतिक चेतना एवं सामाजिक चेतना का विकास हो जाता है। वे आस-पड़ोस की भाषा और आवश्यकता के अनुसार उपयुक्त भाषा-प्रयोग, शब्दों के सुविचारित प्रयोग, भाषा की नियमबद्ध प्रकृति आदि से परिचित हो जाते हैं। इतना ही नहीं, वे विभिन्न विधाओं और अभिव्यक्ति की अनेक शैलियों से भी परिचित हो चुके होते हैं। अब विद्यार्थियों का अध्ययन आस-पड़ोस, राज्य-देश की सीमा को लाँघते हुए वैश्विक क्षितिज तक फैल जाता है। इन विद्यार्थियों की दुनिया में समाचार, खेल, फिल्म तथा अन्य कलाओं के साथ-साथ पत्र-पत्रिकाएँ और अलग-अलग तरह की पुस्तकें भी प्रवेश पा चुकी होती हैं।

एनसीईआरटी के पाठ्यक्रम और पाठ्यपुस्तकों में आर 1 और आर 2 के संदर्भ एनसीसीएफ-एसई 2023 के परिप्रेक्ष्य पर आधारित सांकेतिक और प्रासंगिक हैं। इन संदर्भों का उद्देश्य माध्यमिक

स्तर पर आर1 और आर2 के बीच किसी भी प्रकार का संरचनात्मक या योग्यता-आधारित अंतर दर्शाना नहीं है।

पाठ्यपुस्तक की विषयवस्तु, अधिगम परिणाम और मूल्यांकन माध्यमिक स्तर पर आर1 और आर2 के लिए परिकल्पित सामान्य योग्यता ढाँचे के अनुरूप हैं, इसलिए संदर्भ के अनुसार इन पाठ्यपुस्तकों का लचीले ढंग से उपयोग किया जा सकता है।

इस स्तर पर हिंदी का अध्ययन-अध्यापन साहित्यिक, सांस्कृतिक और व्यावहारिक भाषा के रूप में कुछ इस तरह से हो कि माध्यमिक स्तर तक पहुँचते-पहुँचते यह विद्यार्थियों की पहचान, आत्मविश्वास और विमर्श की भाषा बन सके। आवश्यकता इस बात की है कि विद्यार्थी भाषा के लिखित प्रयोग के साथ-साथ सहज और स्वाभाविक मौखिक अभिव्यक्ति में भी सक्षम हो सकें। वे हिंदी की प्रकृति के अनुसार वर्तनी और उच्चारण के आपसी संबंधों को समझ सकें ताकि उनकी लिखित और मौखिक भाषा में समानता एवं स्पष्टता हो।

CG-1: लेखन के विभिन्न रूपों (निबंध, पत्र, लेख, चर्चा, साक्षात्कार, सार्वजनिक भाषण) और नव मीडिया (ईमेल, श्रव्य और दृश्य सामग्री) के माध्यम से प्रभावी संप्रेषण के लिए भाषा का उपयोग करना।

दक्षताएँ	सीखने के संकेत बिंदु/गतिविधियाँ
C-3.1-विभिन्न श्रव्य और लिखित सामग्री का विश्लेषण और मूल्यांकन करना।	<ul style="list-style-type: none"> विभिन्न प्रकार की श्रव्य और लिखित सामग्री में विवरणों का अवलोकन और विश्लेषण करके उन्हें व्यवस्थित रूप से लिखते हैं। किसी एक विषय पर विभिन्न स्रोतों से प्राप्त सामग्री का विश्लेषण करके उसकी विश्वसनीयता की जाँच करते हैं।
C-3.2-रचना में परिवेश का सावधानीपूर्वक मूल्यांकन करके उचित तर्कों के साथ चर्चा-परिचर्चा करना।	<ul style="list-style-type: none"> पाठ्यवस्तु को पढ़ते और सुनते समय स्वयं के पूर्वग्रहों को पहचानते हैं और साक्ष्यों का मूल्यांकन करके पाठ्यवस्तु/श्रव्य-सामग्री की विश्वसनीयता का निर्धारण करते हैं।

पाठ्यचर्या CG-4: भारतीय भाषाई विविधता से जुड़ी साहित्यिक और सांस्कृतिक विरासत की सराहना करना।

दक्षताएँ	सीखने के संकेत बिंदु/गतिविधियाँ
C-4.1-पाठ को पढ़ते हुए विभिन्न शैलियों की सामग्री के अवलोकन के माध्यम से भारतीय समाज और साहित्यिक विविधता की बहुभाषी प्रकृति की पहचान करना।	<ul style="list-style-type: none"> भारतीय समाज की बहुभाषी प्रकृति को पहचानने के लिए विभिन्न क्षेत्रीय भाषाओं के चलचित्र और वृत्तचित्र देखते हैं और उनके बारे में अपने विचार साझा करते हैं।
C-4.2-भारतीय भाषाओं की विभिन्न साहित्यिक रचनाओं में निहित संस्कृति एवं विरासत की विविधता और उनके आपसी संबंधों की सराहना करना।	<ul style="list-style-type: none"> पढ़ी गई साहित्यिक रचनाओं को विषयों, पात्रों और परिस्थितियों के आधार पर अपने व्यक्तिगत अनुभवों/जीवन से जोड़ते हैं। विभिन्न भारतीय भाषाओं के साहित्य की विशिष्टता और साहित्य जगत में उनके योगदान की सराहना करते हैं।
C-4.3-हमारी संस्कृति और पहचान के निर्माण में भाषा की भूमिका को समझते हुए अभिव्यक्त करना।	<ul style="list-style-type: none"> भाषा में निहित सांस्कृतिक परंपराओं से प्रभावित कहावतों/पहेलियों/मुहावरों के उदाहरण साझा करते हैं। लिखने और बोलने में सांस्कृतिक परंपराओं से प्रभावित अपनी भाषा की शब्दावली का संदर्भों के अनुसार उपयुक्त उपयोग करते हैं।

हिंदी पाठ्यक्रम - आर - 2 (2026 - 27)			
कक्षा - नवीं			
खंड			भारांक
क	अपठित बोध		14
ख	व्यावहारिक व्याकरण		16
ग	पाठ्यपुस्तक		30
घ	रचनात्मक लेखन		20
<ul style="list-style-type: none"> भारांक - 80 (वार्षिक परीक्षा) +20 (आंतरिक परीक्षा) 			

खंड -क (अपठित बोध)		उपभार	कुल भार
विषयवस्तु			
1	अपठित गद्यांश पर बोध, चिंतन, विश्लेषण, सराहना आदि पर बहुविकल्पीय, अतिलघूत्तरात्मक एवं लघूत्तरात्मक प्रश्न		14
	दो अपठित गद्यांश लगभग 200 शब्दों के। एक अंकीय तीन बहुविकल्पी प्रश्न (1x3=3) पूछे जाएँगे अतिलघूत्तरात्मक एवं लघूत्तरात्मक प्रश्न (2x2=4) पूछे जाएँगे ।	7+7=14	
खंड -ख (व्यावहारिक व्याकरण)			
2	व्याकरण के लिए निर्धारित विषयों पर विषयवस्तु का बोध, भाषिक बिंदु /संरचना आदि पर अतिलघूत्तरात्मक एवं लघूत्तरात्मक प्रश्न (1X16 = 16) कुल 20 प्रश्न पूछे जाएँगे, जिनमें से केवल 16 प्रश्नों के उत्तर देने होंगे ।		16
(i)	(क) शब्द भंडार समानार्थी शब्द - 2 अंक (पाठ्यपुस्तक के आधार पर) (3 प्रश्नों में से 2 प्रश्न करने होंगे) (ख) मुहावरे -2 अंक (पाठ्यपुस्तक के आधार पर) (3 प्रश्नों में से 2 प्रश्न करने होंगे)	4	
(ii)	शब्द -निर्माण उपसर्ग - 2 अंक ,प्रत्यय -2 अंक (5 प्रश्नों में से 4 प्रश्न करने होंगे)	4	
(iii)	विराम चिह्न - 2 अंक (3 प्रश्नों में से 2 प्रश्न करने होंगे)	2	
(iv)	संज्ञा -2 अंक सर्वनाम -2 अंक निपात -2 अंक (7 प्रश्नों में से 6 प्रश्न करने होंगे)	6	
3	खंड -ग (पाठ्यपुस्तक)		30

4	खंड -घ (रचनात्मक लेखन)		20
	लेखन		
	(i)	विभिन्न विषयों और संदर्भों पर विद्यार्थियों के तर्कसंगत विचार प्रकट करने की क्षमता को परखने के लिए संकेत-बिंदुओं पर आधारित समसामायिक एवं व्यावहारिक जीवन से जुड़े हुए तीन विषयों में से किसी एक विषय पर लगभग 100 शब्दों में अनुच्छेद लेखन ।	5
	(ii)	अभिव्यक्ति की क्षमता पर केंद्रित अनौपचारिक दो विषयों में से किसी एक विषय पर लगभग 100 शब्दों में पत्र लेखन । (विकल्प सहित)	5
	(iii)	दिए गए विषय / परिस्थिति के आधार पर लगभग 80 शब्दों में संवाद लेखन । (विकल्प सहित)	5
	(iv)	किसी दृश्य /घटना के चित्र पर आधारित लगभग 80 शब्दों में लेखन । (बिना किसी विकल्प के)	5

राष्ट्रीय शैक्षिक अनुसंधान केंद्र द्वारा राष्ट्रीय पाठ्यचर्या की रूपरेखा 2023 के आधार पर जारी की गई पाठ्यपुस्तक के आधार पर साहित्य से संबंधित अध्ययन किया जाए।

Science at Advanced Level (Optional)

Grade 9

2026-27

**Academic Unit,
Central Board of Secondary Education**

Integrated Office Complex, Sector-23, Phase - 1, Dwarka,
New Delhi - 110077



Table of Contents

S. No.	Chapters	Pages
1.	Measurement – Foundation of Science	4-8
2.	Understanding Motion through Experience	9-14
3.	Newton's Laws of Motion	15-24
4.	The Geometry of Power – Advanced Simple Machines	25-29
5.	Work and Energy	30-33
6.	Structure of Atom	34-41
7.	Chemical Bonding	42-48
8.	Mixtures and their Separation	49-53
9.	Microscope and Microscopy	54-69
10.	Engineering Life: Miracles in Biotechnology	69-86

Content Development Committee

Mr. Aishwary Meet, Physics Expert, Gaur International School, Noida

Ms. Alka Gupta, TGT Science, Mayoor School, Sector-126, Noida

Dr. Amit Sehgal, Professor, Hansraj College, University of Delhi

Dr. Anita Verma, Retired Professor, Kirori Mal College, University of Delhi

Ms. Cenkush Sharma, TGT, Vandana International School, Dwarka, Delhi

Ms. Geetanjali Padhy, Biology Educator, Suncity School, Sector-54, Gurugram

Dr. Girish Choudahry, Retd. Associate Professor, Lady Irwin College, University of Delhi

Professor K.K Arora, Professor, Zakir Husain College, University of Delhi

Ms. Mridula Arora, Head of School, Navayug School, Sarojini Nagar, New Delhi

Ms. Pamila Marwaha, PGT Chemistry, Navayug School, Sarojini Nagar, New Delhi

Dr. Renu Parashar, Professor, Hansraj College, University of Delhi

Dr. Sanjeev, Professor, IGNOU

Ms. Shivani Kaplish, TGT Science, Mayoor School, Sector-126, Noida

Ms. Varsha Krishnan, TGT, Bal Bharati Public School, Rohini, Delhi

Measurement- The Foundation of Science

1.1 Introduction: What is Measurement?

Measurement is the process of comparing an unknown quantity with a known standard quantity of the same kind. Physics is based on measurement. Whether we measure the length of a classroom, the mass of a bag, or the time taken by a runner, accurate measurement is essential

Examples

- A tailor measures cloth in meters.
- A doctor measures body temperature in degree Celsius.
- A shopkeeper measures rice in kilograms.

Without proper units, these measurements would have no meaning.

Activity 1.1 Measuring the area of the classroom floor

Materials: Take three sticks of length $l_1:l_2:l_3 = 1:2:3$

Procedure:

1. Divide students in 3 groups and hand over one stick to each group.
2. Each group will measure the length and width of the classroom taking stick as one unit.

	Stick 1	Stick 2	Stick 3
Length of wall units* units units
Breadth of wall units units units
Area of floor units ² units ² units ²

**the unit refers to length of the stick used for measurement*

3. Compare the length, breadth and area measured by different groups and try to generate conclusions between unit chosen and numerical values obtained by all the three groups.

This activity demonstrates that the numerical value of a quantity is inversely proportional to the size of the unit used. Thus, when a larger unit (longer stick) is used to measure the classroom floor, the numerical value obtained is smaller, and

when a smaller unit is used, the numerical value is larger.

In measurement, the physical quantity remains constant even when the unit changes.

Hence,

$$Q = n_1 u_1 = n_2 u_2$$

Therefore,

$$n_2 = n_1 (u_1 / u_2)$$

Activity 1.2: Let's play an estimation game

Procedure:

1. Estimate the length of the blackboard without measuring.
2. Then measure its length using a meter scale.
3. Compare the estimated and measured values. Now, calculate the inaccuracy (error) in the measurement.

1.2 Different Systems of Units

In earlier times, different regions/places used their own units of measurement, which often led to confusion and errors.

(a) CGS System

- Length: centimeter (cm)
- Mass: gram (g)
- Time: second (s)

It is mainly used in laboratory and scientific calculations.

(b) FPS System

- Length: foot (ft)
- Mass: pound (lb)
- Time: second (s)

Commonly used in the United States.

(c) MKS System

- Length: meter (m)
- Mass: kilogram (kg)
- Time: second (s)

This system later developed into the SI (**International System of Units or *Système International d'Unités***) system.

Example

- The height of a person is largely measured in centimeters in India, while in some countries it is measured in feet and inches.

1.3. Need for a Common System of Units

Different systems of units caused difficulties in communication, trade, and scientific research.

Problems Without a Common System

- Confusion in international trade
- Errors in scientific calculations
- Difficulty in sharing scientific data

Example

If a scientist in India measures length in meters and another in the USA measures in feet, comparison becomes difficult unless a common unit is used.

Hence, a universal system of units was required.

Activity 1.3: Let us Compare

Materials: Ruler marked in cm and inches

Procedure:

1. Measure the length of a book using both cm and inches.
2. Compare the values and find the relation between them.

1.4. International System of Units (SI)

The International System of Units (SI) is the modern and universally accepted system of measurement.

SI Base Units

Physical Quantity	SI Unit	Symbol
Length	Meter	m
Mass	Kilogram	kg
Time	Second	s
Temperature	Kelvin	K
Electric Current	Ampere	A

Luminous Intensity	Candela	Cd
Amount of substance	Mole	mol

Advantages of SI Units

- Internationally accepted
- Easy to use and understand
- Based on the decimal system

Examples

- Speed of vehicles is measured in m/s or km/h
- Medicines are measured in milligrams (mg)

1.5 Conversion of Units between different Systems

Sometimes, we need to convert a measurement from one unit to another to ensure comprehension across different systems.

During unit conversion, the numerical value and the unit may change, but the magnitude of the physical quantity remains the same.

Basic Conversions

- **1 km = 1000 m**
- **1 m = 100 cm**
- **1 kg = 1000 g**
- **1 hour = 3600 s**

Examples

Q. Convert 9 km/hr into m/s.

$$\text{Answer: } 9 \text{ km/hr} = \frac{9 \times 1000 \text{ m}}{3600 \text{ s}} = \frac{5}{2} \text{ m/s}$$

Q. Convert 1 N into gcm/s².

$$\text{Answer: } 1 \text{ kg m/s}^2 = 1000\text{g} \times 100 \text{ cm/s}^2 = 10^5 \text{ gcm/s}^2 = 10^5 \text{ dyne.}$$

Quick Check

1. Name any two systems of units.
2. Why is SI system preferred over other systems?
3. Convert 250 N into gcm/s².
4. Convert 1000 kg/L into kg/m³.

Check Your Understanding

1. Which of the following is not an SI unit?
 - a) Meter
 - b) Kilogram
 - c) Second
 - d) foot
2. The SI unit of mass is:
 - a) Gram
 - b) Kilogram
 - c) Pound
 - d) tonne
3. Name the system of units used internationally.
4. Why is a common system of units necessary?
5. Why is measurement necessary in physics?
6. Why was there a need for a common system of units?
7. Explain the relation: Magnitude = Numerical value \times Unit
8. Why does the same classroom floor give different numerical values when measured with sticks of different lengths?

Answer questions 9 to 11 that are based on Activity 1.1 (Measuring Classroom Floor)

Suppose:

Stick Length	Length of Wall	Breadth of Wall
1 unit	30 units	20 units
2 units	15 units	10 units
3 units	10 units	6.6 units

9. Why are numerical values different?
10. Is the actual size of the classroom different? Why or Why not?
11. What conclusion can you draw about units and measurement from this activity?
12. Fill in the blanks
 - a. Measurement is the process of comparing an unknown quantity with a _____ quantity.
 - b. The SI unit of mass is _____.

- c. In CGS system, the unit of length is _____.
- d. 1 km = _____ m.
- e. The modern internationally accepted system of units is called _____.

13. Match the following:

Column A	Column B
CGS	Kelvin
FPS	Pound
SI	International system
MKS	Meter-Kilogram-Second

- 14. What problems might occur if every country used its own system of units for measurement?
- 15. A scientist measures length in feet and another in meters. What difficulties may it lead to?
- 16. If 1 meter was defined differently in different countries, what would happen to international trade?
- 17. A shopkeeper sells rice using kilograms. A foreign customer asks for rice in pounds.
 - a. Why is unit conversion necessary here?
 - b. If 1 kg = 2.2 pounds, how many pounds are there in 5 kg?

Understanding Motion Through Experience

Reflect on the following:

- Why do we feel pushed backward when a bus suddenly starts moving?
- Can an object be at rest for one observer but moving for another?
- How do athletes decide the best angle to throw a ball so that it travels the maximum distance?
- Can we measure motion using simple tools available in the classroom?

Discuss your ideas with classmates before beginning the activities.

2.1 What is Motion?

An object is said to be in motion if its position changes with time with respect to a reference point. Motion can be slow or fast, straight or curved, uniform or non-uniform. Understanding motion becomes easier when we observe it directly and measure it ourselves.

Activity 2.1: Let's observe

Materials: Notebook, stopwatch (mobile timer), measuring tape

Steps:

1. Mark two points 5 meters apart in the classroom corridor or playground.
2. Ask one student to walk normally from one point to another while another student measures the time taken using a stopwatch.
3. Repeat the experiment with the student running.
4. Record the distance and time in a table.

Observation: - Compare the time taken for walking and running. - Which motion is faster? How can you calculate speed?

Can motion be described using measurable quantities such as distance and time?

2.2 Frame of Reference

A frame of reference that is at rest or moving with constant velocity is called an inertial frame. Newton's laws hold without modification in such frames. A frame that is accelerating is called a non-inertial frame, and we will see in later sections that special corrections (pseudo forces) become necessary in such frames.

To describe the state of motion of an object, we must specify a reference point. Without it, we cannot say whether an object is moving or at rest.

Activity 2.2: Motion is Relative

Materials: Two students as props

Steps:

1. Let one student stand still while another walks past him.
2. Ask each student to describe the motion of the other student.
3. Now let both students walk in the same direction with the same speed and describe the motion again.

Discussion: - When both students walk together at the same speed, they appear at rest relative to each other but moving relative to the classroom.

2.3. Scalars and Vectors

Physical quantities are of two types: -

Scalars: Quantities having magnitude only (distance, time, mass, speed and work)

Vectors: Quantities having both magnitude and direction (displacement, velocity, force).

Activity 2.3: Direction Matters

Materials: Chalk, measuring tape

Steps:

1. Draw a straight 5-metre line on the ground and mark the starting point as A and the end as B.
2. Walk from A to B and note the distance covered.
3. Next walk from A to B and then back to A.
4. Compare the distance travelled and displacement.

Observation: - Distance changes but displacement becomes zero when returning to the starting point.

2.4 Vector Addition (Graphical Method)

Vectors are physical quantities that have both magnitude and direction, such as displacement, velocity, and force. When two or more vectors act together, we combine them to find a single vector called the **resultant**. This process is known as **vector addition**. Vectors can be added graphically using methods like the **triangle method** or the **parallelogram method**.

Activity 2.4: Graphical Addition of Displacements

Materials: Graph paper, ruler, pencil

Steps:

1. On graph paper, draw a vector representing 4 units towards the east.
2. From the head (end) of this vector, draw another vector representing 3 units towards the north.
3. Now join the tail (starting point) of the first vector to the head of the second vector.

Observation:

The line joining the starting point to the final point represents the **resultant displacement**.

This is how two vectors can be combined graphically to find a resultant vector, and how both magnitude and direction are important in describing motion.

Practice Question:

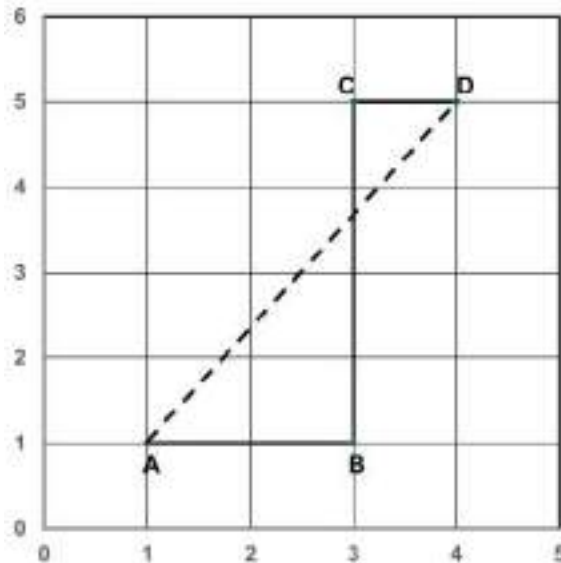

Points A at (1,1), B at (3,1) , C at (3,5) and D at (4,5) (All the values mentioned in the graph are in km) represent Sita's House, bus stop, traffic signal and school respectively. In the morning Sita travels from A to B on foot, then B to D via C in the school bus. (All the values mentioned in graph are in km) Then calculate:

- (a) Distance traveled by Sita on foot,
- (b) Distance traveled by Sita by the school bus,
- (c) Total displacement of Sita from her house to the school.

2.5. Equations of Motion

When an object moves with constant acceleration, its motion can be described using equations which are given as:

$$V = u + at$$

$$S = ut + \frac{1}{2}at^2$$

$$v^2 = u^2 + 2as$$

where, u is initial velocity, v is final velocity, a is acceleration, and s is displacement.

Activity 2.5: Observing Accelerated Motion Using a Toy Car

Materials: Toy car (or small wheeled object), smooth floor, measuring tape, stopwatch (mobile timer), chalk/tape

Steps:

1. Mark a straight line on the floor and label the starting point as O.
2. Place the toy car at point O and give it a gentle push so that it moves forward.
3. Use a stopwatch and note the position of the car at equal time intervals (every 1 second).
4. Mark these positions on the floor using chalk or tape.
5. Measure the distance from the starting point to each marked position and record it in a table.

Observation: The distance travelled in successive intervals increases, showing acceleration.

Conclusion:

The motion is **accelerated motion**, as the velocity increases with time.

4th equation of motion distance travelled in the n^{th} second

From the **second equation of motion**:

$$s = ut + \frac{1}{2}at^2$$

where,

u = initial velocity

a = acceleration

t = time

s = displacement in time t

Distance travelled in n seconds

$$s_n = u(n) + \frac{1}{2}an^2$$

Distance travelled in (1) second

$$s_{n-1} = u(n-1) + \frac{1}{2}a(n-1)^2$$

Distance travelled in the n^{th} second

$$\text{distance in } n^{\text{th}} \text{ second} = s_n - s_{n-1} = \left[\frac{1}{2}an^2 \right] - \left[u(n-1) + \frac{1}{2}a(n-1)^2 \right]$$

Solving:

$$= un + \frac{1}{2}an^2 - un + u - \frac{1}{2}a(n^2 - 2n + 1) = u + \frac{1}{2}a[2n - 1]$$

Final Formula

$$s_n = u + \frac{a}{2}(2n - 1)$$

This is the distance travelled in the n^{th} second, often called the fourth equation of motion. Here n must be a positive integer representing the n th second of motion. The formula gives the displacement specifically during that one-second interval, not a cumulative displacement.

2.6 Reflect and Discuss

- Why is specifying a reference frame necessary to describe motion?
- How do direction and magnitude together describe displacement?
- Which daily activities around you involve accelerated motion?

2.7 Project-Based Learning

Design a simple experiment using everyday materials to measure the speed of a moving object (using a bicycle, or a walking student). Present your method, observations, calculations, and conclusions to the class.

Check Your Understanding

1. Define a frame of reference in your own words.
2. Give two real-life examples where motion depends on the observer.
3. Why does a person sitting in a moving train appear at rest to another passenger?
4. Classify the following as scalar or vector quantities: speed, velocity, displacement, distance, acceleration and mass.

5. Explain the difference between distance and displacement with an activity diagram.
6. Give two everyday examples of vector quantities.
7. Draw two vectors of 4 units east and 3 units north and find the resultant using the triangle method.
8. Explain how vector subtraction is performed graphically.
9. Draw two opposite vectors of equal magnitude. Calculate its resultant.
10. A body starts from rest and accelerates at 4 m/s^2 . Find the distance travelled in the 6th second.
11. A car with initial velocity 8 m/s accelerates at 2 m/s^2 . Find the distance covered in the 5th second.

Newton's Laws of Motion

3.1 Limitations of Newton's Laws in Accelerating Frames

Activity 3.1: Let us observe

Consider the following situations:

- A passenger standing in a bus that suddenly accelerates forward feels pushed backward, even though no one is actually pushing.
- When a vehicle takes a sharp turn, passengers feel pushed outward.

Why does this happen? Is there really a force pushing the passenger backward or outward? Can these effects be explained only by the usual forces like gravity or friction?



Understanding the Limitations

According to Newton's First Law of Motion, a body continues to remain at rest or in uniform motion in a straight line unless acted upon by an external force. This law is strictly valid only in a non-accelerating frame.

However, when the frame itself is accelerating, objects seem to move without any visible external force acting on them.

To maintain consistency with Newton's laws, let us examine an additional concept.

Pseudo Force (Fictitious Force)

A force which does not arise due to physical contact or interaction (unlike gravitational, frictional, or tension forces). A pseudo force (also called a fictitious force) is an apparent force that is observed only when motion is described from an accelerating frame of reference.

Now understanding the scenario: What does a passenger fall backwards when a bus starts suddenly?

Observer 1: Standing on the road (inertial frame)

- Sees the bus accelerate forward
- Sees the passenger trying to remain at rest (inertia)

Explanation uses only real physics:

- No backward force exists
- Passenger's body just resists motion

This follows Newton's First Law of Motion perfectly.

Observer 2: Inside the accelerating bus (non-inertial frame)

- Sees the passenger "move backward"
- But doesn't see any real force causing it

To make Newton's Laws of Motion still work, we **introduce the concept of pseudo force**: From the ground (an inertial frame), no force pushes the passenger backward — the bus simply accelerates away from under them. But if we describe the situation from inside the accelerating bus (a non-inertial frame), we must add a pseudo force of magnitude $m \cdot a$ directed backward to make Newton's First Law appear valid within that frame. This force has no physical source and no reaction pair.

When a frame accelerates forward, it exerts an influence on objects inside it. From within that accelerating frame, we introduce an imaginary force acting in the opposite direction to explain the observed motion. Thus, in an accelerating frame:

- The frame accelerates in one direction.
- An apparent force (pseudo force) is considered to act on the body in the opposite direction.

This ensures that Newton's First Law still appears valid within that frame.

Definition:

A pseudo force is an apparent force observed only in an accelerating frame of reference.

It is always opposite to the acceleration of the frame and does not arise due to any physical interaction.

Formula

$$F_{pseudo} = -ma_{frame}$$

where:

- m = mass of the object
- a_{frame} = acceleration of the frame
- The negative sign indicates that the pseudo force acts opposite to the acceleration of the frame.

Quick Check

1. In which type of reference frame are Newton's laws valid?
2. Define pseudo force and write its formula.
3. A lift accelerates upward at 4.5 m s^{-2} . Calculate the pseudo force experienced by a 60 kg person inside the lift.
4. Why does pseudo force disappear in an inertial frame?

3.2 Gravitation

Orbital Motion: Why the Earth and Moon Do Not Fall Despite Gravity?

Concept of Centripetal and Centrifugal forces

The Sun and the Earth both have mass, so they attract each other with a gravitational force. According to Newton's law of gravitation, the force between them is equal in magnitude and opposite in direction. However, because the Sun's mass is much greater than the Earth's mass, the Earth experiences a much larger acceleration as compared to the Sun. That is why the Earth appears to revolve around the Sun.

The Sun's gravitational pull on the Earth provides the centripetal force needed to keep the Earth in its orbit.

Earth is revolving around the Sun and it is moving with very high tangential velocity. So, due to its inertia, it should tend to continue moving in a straight line. On the other hand, the gravitational force of the sun is continuously attracting it towards the centre of the sun. This changes its direction of motion. As a result of these two aspects, the Earth does not move in a straight line but follows a fixed curved path called an orbit.

Let us think: Imagine the Earth suddenly slows down. Take a moment to picture what would happen if its forward (tangential) speed decreases, but the Sun's gravitational pull remains just as strong as before. Would the balance still exist? How would this change affect the Earth's path? Think about why slowing down would cause the Earth to drift closer to the Sun instead of continuing smoothly along its usual orbit.

Try to get the answer with the help of the following activity.

Activity 3.2:

Steps:

1. Tie the ring/bob securely to one end of the thread of length approx. 1 m.
2. Hold the other end of the thread firmly with your finger.
3. Swing the ring/bob in a horizontal circle at a steady speed.

4. Observe how the bob moves in a circular path.
5. Now slowly reduce the speed of rotation.
6. Continue decreasing the speed further and observe what happens to the circular motion.

Observation:

At an appropriate speed, the thread provides the centripetal force that pulls the stone/ bob inward, keeping it in a circular path. At the same time, due to its inertia, the stone tends to move in a straight line along the tangent. The balance between this outward tendency and the inward centripetal force results in circular motion.

When the speed decreases, the **required centripetal force also decreases**. However, the tension in the thread may reduce to the point where it can no longer keep the stone moving in a circular path. As a result, the string may become slack, and the motion is no longer circular—the stone begins to move inward or fall.

Conclusion:

Circular motion requires a balance between inward pulling force (centripetal force) and tangential speed (which provides necessary centrifugal force). If speed decreases too much, the balance is disturbed, and the object can no longer continue in the same circular path.

Effect of Cross-Sectional Area (Air Resistance) on Falling Objects of Equal Mass

Let us imagine two objects with the same mass but different cross-sectional areas. These are dropped from the same height, an important question arises: *Will they reach the ground at the same time?*

Case 1: When Air Is Present

Both objects have the same mass, so the gravitational force acting on them is the same:

$$F = mg$$

Since mass (m) is the same, the force of gravity on both objects is equal. This means gravity pulls both objects downward equally.

However, another force also acts on the objects — **air resistance (air drag)**. This is an upward force that opposes motion.

Air resistance mainly depends on the **cross-sectional area** of the object (and shape, speed and density of air). The larger the cross-sectional area, the greater the air resistance.

Because of this:

- The object with a **larger cross-sectional area** experiences more air resistance.
- The object with a **smaller cross-sectional area** faces less opposition.
- Therefore, it has a greater net downward force and falls faster.

Conclusion:

In air, the object with the **smaller cross-sectional area** reaches the ground first.

Case 2: In a Vacuum (No Air)

Since there is no air in a vacuum, there is **no air resistance either**.

$$a = \frac{F}{m} = \frac{mg}{m} = g$$

Conclusion:

In a vacuum, both objects reach the ground at the **same time**, regardless of their shape or size.

Variation of acceleration due to Gravity with Altitude and Depth (without using Binomial Theorem)

- When we throw a ball upward, it comes back down.
- When we jump, we return to the ground.

This happens because the Earth pulls everything toward its centre due to gravity.

But why do astronauts float inside a spacecraft?

Does gravity disappear in space?

Is the value of gravity the same everywhere?

We know that as we go higher above the Earth's surface, we move farther away from the centre of the Earth. We know that gravitational force depends on distance. As distance increases, force decreases.

Astronauts in the International Space Station appear weightless.

So clearly, gravity decreases with height, but it does not become zero.

Now let us derive the expression for the acceleration due to gravity at point A, which is at a height of h from the surface of the earth.

Derivation – Acceleration Due to Gravity at Height

Let:

- Mass of object = m
- Radius of Earth = R
- Height above surface = h
- Distance from centre of Earth = $(R + h)$

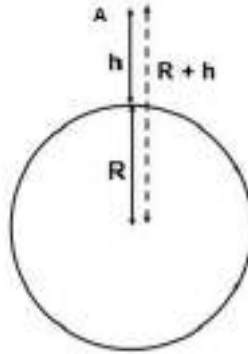

Fig: 3.1 Acceleration due to gravity at height h

The acceleration due to gravity at height h is:

$$g_h = \frac{GM}{(h)^2}$$

Where:

- G = Universal Gravitational Constant
- M = Mass of Earth

On Earth's surface:

$$g = \frac{GM}{R^2}$$

Dividing both equations:

$$\frac{g_h}{g} = \frac{R^2}{(h)^2}$$

This shows clearly that:

$$g_h < g$$

Example

Calculate acceleration due to gravity at a height of 800 km above Earth.

Given:

$$R = 6400 \text{ km}$$

$$h = 800 \text{ km}$$

$$g = 9.8 \text{ m/s}^2$$

$$g_h = g \left(\frac{R^2}{(h)^2} \right) g_h = 9.8 \left(\frac{6400^2}{7200^2} \right) g_h = 9.8 \left(\frac{64}{72} \right)^2 g_h = 7.74 \text{ m/s}^2$$

Acceleration Due to Gravity Below the Surface of Earth

Now, consider a point **A** located at a depth **d** inside the Earth. Assuming the Earth has uniform density, let us determine the acceleration due to gravity at that interior point.

Let:

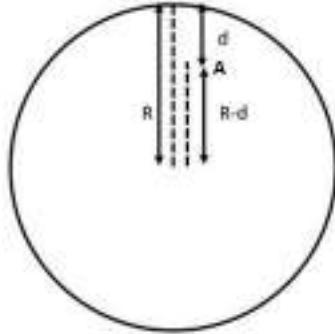

Fig: 3.2 Acceleration due to gravity at depth d

- Radius of Earth = R
- Depth below surface = d
- Distance from centre = (R - d)
- Density of Earth = ρ (uniform)

If density is uniform, then mass of the earth can be calculated by

$$\text{Mass of Earth} = M = \frac{4}{3} \pi R^3 \rho$$

At depth d, the object is at a distance (R - d) from the centre, only the mass inside radius (R - d) contributes to gravity. (This is By Newton's Shell theorem, the gravitational effect of a uniform spherical shell on a point inside it is exactly zero. Therefore, at depth d, only the sphere of radius (R-d) centred at Earth's core contributes to gravity—the outer shell of thickness d has no net effect)

$$M_d = \frac{4}{3} \pi (R - d)^3 \rho$$

From Newton's Law of Gravitation

$$g_d = \frac{GM_d}{(d)^2}$$

Substitute M_d :

$$g_d = \frac{G \left(\frac{4}{3} \pi (R - d)^3 \rho \right)}{(d)^2}$$

$$g_d = \frac{4}{3} \pi G \rho (R - d)$$

Compare with gravity at earth's surface i.e.

At Earth's surface:

$$g = \frac{4}{3} \pi G \rho R$$

Dividing the two equations:

$$\frac{g_d}{g} = \frac{R - d}{R}$$

Therefore,

$$g_d = g \left(\frac{d}{R} \right)$$

We conclude from the above derivations that acceleration due to gravity is maximum at the Earth's surface and decreases as we go up/down. It will become zero at the centre of the earth.

Example:

At what depth does g become 1/10th of its surface value?

Given:

$$g_d = \frac{g}{10}$$

Using the formula:

$$g \left(\frac{d}{R} \right) = \frac{g}{10} \Rightarrow 1 - \frac{d}{R} = \frac{1}{10} \Rightarrow \frac{d}{R} = \frac{9}{10} \Rightarrow d = \frac{9R}{10}$$

Quick Check

1. Where does the acceleration due to gravity reach its maximum value—on the surface, above, or below the Earth?
2. What happens to g at the centre of the Earth?
3. Calculate g at a height of 400 km if R = 6400 km.
4. At what depth will g become half of its surface value?
5. Why does gravity decrease both above and below the surface of the earth?

3.3 Turning Forces (Moment of Force/Torque)

Activity 3.3: Let us observe

Look at the picture of a boy trying to enter his classroom. He pushes the door to open it.



Now, think carefully and answer the following questions:

- Where will the boy apply force to open the door easily?
 - (a) Near the handle
 - (b) Near the hinges
 - (c) At the centre of the door
- Why are door handles fixed far away from the hinges and not near them?

Now, reflect on the following points:

- The boy applies force in a straight direction, but the door rotates. Why does this happen?
- Even though the door is heavy, it rotates easily when pushed at the handle.
- How is it possible to rotate such a heavy object by applying force at just one end?

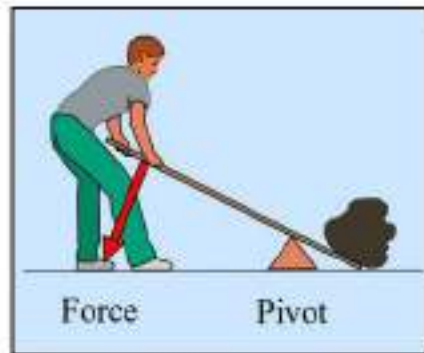
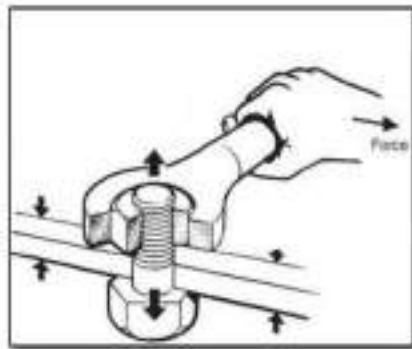

Fig: 3.3 Some examples of turning effects of forces in our daily life

When we apply a force to an object and it starts to rotate, the force produces a turning effect.

This turning effect of a force is called the moment of force.

Moment of Force (Torque) $\tau = F \times d \times \sin \theta$, where F is the magnitude of the force, d is the distance from the pivot to the point of application, and θ is the angle between the force and the line joining the pivot to the point of application. Torque is maximum when $\theta = 90^\circ$ (force perpendicular to the lever arm) and zero when $\theta = 0^\circ$ or 180° (force directed toward or away from the pivot).

Since the turning effect of a force depends on both the magnitude of the force and the distance from the fixed point, its S.I. unit is newton-metre (Nm).

The angle at which force is applied to a door (and the resulting angle of the door itself) is crucial for controlling the turning, efficiency, and safety of the opening motion. The fundamental principle is that turning is maximized when the force is applied perpendicular (at a 90-degree angle) to the door surface, making it the most efficient way to open or close it.

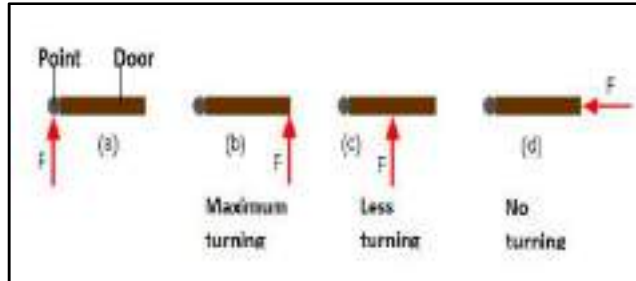

Check Your Understanding

1. Why is it easier to open a door when you push at the handle rather than near the hinges?
2. A force is applied to a wrench at different angles. At which angle will the rotating force be maximum? What happens to the turning effect when the force is applied parallel to the wrench?
3. Two students apply the same force to open a gate. One pushes perpendicular to the gate at 20cm from the hinge. The other pushes perpendicular to the gate at 80 cm. Who produces greater torque? Justify
4. Is it possible for a force to act on a body and still produce zero turning about a given fixed point? Give a real-life example.
5. Two forces act on a rod pivoted at its centre:
 - I. 10 N downward at 0.5 m on the left
 - II. 10 N downward at 0.5 m on the right
 Will the rod rotate? Explain your reasoning
6. How can a mechanic loosen a tight bolt using a long spanner instead of applying a very large force? Explain using the torque formula.
7. A force of 20 N is applied to a door at 0.8 m from the hinge. Calculate the torque when the force is applied at (a) 90°, (b) 60° (c) 30° to the door surface.

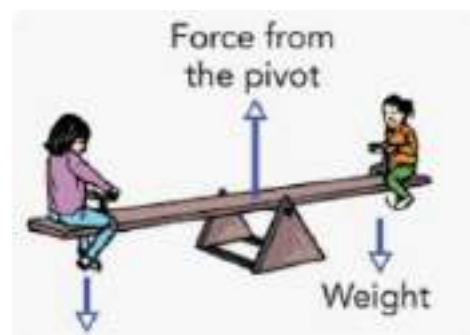

The Geometry of Power- Advanced Simple Machines

4.1 Introduction

Welcome to the study of Mechanical Advantage. While simple machines such as levers and inclined planes form the foundational concepts of physics, the machines that shape our modern world—like cranes, trucks, and bicycles—apply these same principles in more advanced and integrated ways through systems of wheels, axles, and pulleys.

In this chapter, we will examine how the principles of geometry and force distribution allow a relatively small input force to be transformed into a much larger output force.

Activity 4.1:

- A truck driver turning a massive vehicle using only two hands.
- A crane lifting heavy concrete beams smoothly.
- A cyclist moving very fast by pedaling lightly.

Now think carefully:

- Is the driver extremely strong?
- Does the crane create extra force?
- Does the cyclist get “free” speed?

In all these cases, machines are helping us multiply force or increase speed.

This multiplication is called **Mechanical Advantage (MA)**.

4.2 Wheel and Axle – The Steering Mastery

Activity 4.2: Think and Answer

“Think about a steering wheel and axle (steering column) and their respective radius.”

- The steering wheel is large. The steering column connected to it is small. Why is this so?
- Why not make both of equal size?

A wheel and axle consist of:

- a large wheel
- a smaller axle fixed at the center

Both rotate together. When effort is applied on the wheel, torque increases at the axle.

The Mechanical Advantage is calculated using the formula:

$$M.A = \frac{\text{Radius of wheel}}{\text{Radius of Axle}}$$

Example

A driver needs to maneuver the truck on muddy ground, requiring a resistance force of 1,200 N to turn the steering axle. The steering wheel has a radius of 30cm, and the steering axle has a radius of 3cm.

- a) Calculate the Mechanical Advantage (MA) of the steering system.
- b) How much effort (E) must the driver apply to the rim of the steering wheel to turn the truck?

Solution:

$$\begin{aligned} \text{a) } M.A &= \frac{\text{Radius of wheel}}{\text{Radius of Axle}} \\ &= \frac{30 \text{ cm}}{3 \text{ cm}} = 10 \end{aligned}$$

$$\begin{aligned} \text{b) } \text{Effort (E)} &= \frac{\text{load}}{M.A} \\ &= \frac{1200N}{10} = 120N \end{aligned}$$

The driver needs to apply an effort of 120N to the rim of the steering wheel to turn the truck.

Note: In practice, some input work is lost to friction within the machine. The efficiency of a machine is defined as $\eta = (\text{useful output work} / \text{total input work}) \times 100\%$. A real machine always has $\eta < 100\%$. Mechanical Advantage as calculated here assumes an ideal (frictionless) machine.

Quick Check

In a mechanical watch, a single power source (a spring or motor) must move three different hands at three different speeds. This is achieved through a **Gear Train**, where the "output" of one gear becomes the "input" for the next. The seconds-to-minutes gear ratio is 60:1 and the minutes-to-hours ratio is 60:1;

1. If the seconds gear is 2 mm, how large would the hour gear be in meters?
2. Which of the three hands gear should be directly connected to the motor? Why?

4.3 Tension

Activity 4.3:

Hang a thread from an iron stand as shown in figure. Observe its natural length.

Now attach a small bob to the lower end of the thread. Notice how the thread stretches slightly.

Replace the small bob with a heavier bob. Does the stretch increase or decrease?

You will observe that the thread stretches more when a heavier bob is attached. This shows that a greater pulling force is acting on the thread.



Further,

Pass the thread over a pulley. Attach a weight to one side and observe.

Now attach equal weights (equal bobs) on both sides of the pulley. Does the rope move, or does it only stretch?

Replace one of the equal bobs with a heavier bob on the left side. Observe carefully the direction in which the system moves.

When both sides have equal weights, the system remains at rest because the forces are balanced. When one side is heavier, the system moves toward the heavier side.



Tension

Tension is the pulling force/ stretch force that travels through a stretched string, thread, rope, or cable. When you hang an object using a thread, the object pulls the thread downward because of its weight. In response, the thread pulls the object upward. This pulling force inside the thread is called tension. If the weight attached to the string increases, the tension in the string also increases.

It always acts along the length of the string and pulls away from the object to which it is attached.

S.I unit of tension is Newton.

When the forces acting on an object are balanced (for example, the upward tension is equal to the downward weight), the object remains at rest or moves with constant speed. This state is called **equilibrium**. In a pulley system, if equal

weights are placed on both sides, the tensions balance and the system does not move. But if one side is heavier, the forces become unbalanced, and the system moves toward the heavier side. This is by Newton's First Law of Motion.

Let us Calculate: Tension and acceleration are produced when two unequal masses are connected over a pulley.

1. Do the setup of weights, string and simple pulley as shown.

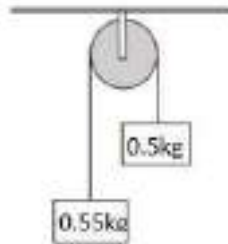

2. Since $0.55 \text{ kg} > 0.5 \text{ kg}$, the 0.55 kg mass will move downward. The 0.5 kg mass will move upward. Both masses will move with the same acceleration because they are connected by the same string.
3. For 0.55 kg mass (moving downward):
 - a. Downward force = Weight = _____
 - b. Upward force = Tension (T)
4. Net force: $0.55g - T = 0.55a$
5. For 0.5 kg mass (moving upward):
 - a. Downward force = Weight = _____
 - b. Upward force = Tension (T)
6. Net force: $T - 0.5g = 0.5a$
7. Add both equations: _____
8. Acceleration of the system: _____
9. Find Tension: _____

Examples:

1. A 5 kg object is suspended stationary from a rope. Calculate the tension.

Ans: The weight of the object is: $T = m \times g = 5 \times 9.8 = 49 \text{ N}$

2. A 4 kg mass is lifted upward with an acceleration of 2 m/s^2 . Calculate the tension.

Ans: Using Newton's Second Law

$$T - mg = ma \quad T = m(g + a) \quad T = 4(9.8 + 2) \quad T = 47.2 \text{ N}$$

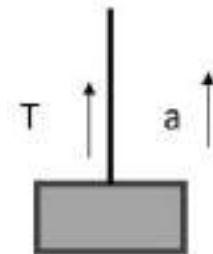

Check Your Understanding :

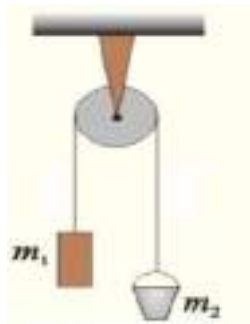

1. Show the direction of weight and tension for both objects m_1 and m_2 .
2. An 8 kg mass hangs freely from a single fixed pulley. The system is at rest. Find the tension in the rope.
3. Observe the given diagram. Find out in which direction the rope will move? What will be the net downward force?

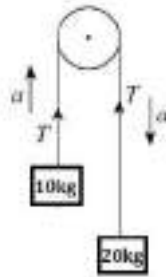

4. A 6 kg mass hangs freely from a single fixed pulley. The system is at rest. Find the tension in the rope.
5. Two objects having masses 2 kg and 6 kg are connected over a frictionless pulley with the help of rope. Find acceleration and tension in the rope.

Work and Energy

5.1 CONSERVATIVE AND NON-CONSERVATIVE FORCES

Recollect these common occurrences:

- A ball thrown upward comes back down to your hand.
- A stretched rubber band returns to its original shape.
- A sliding book on a table finally stops.

Now think carefully:

- Why does the ball come back?
- Why does the rubber band regain its shape?
- Why does the book stop moving?

In all these cases, forces are acting. But are all these forces the same?

Conservative Forces

- If the work done by the force doesn't depend on the path.
- Work done by the force on the closed path is always zero.
- For a conservative force, the work done by the force equals the decrease in potential energy: $W = -\Delta U = -(U_{\text{final}} - U_{\text{initial}}) = U_{\text{initial}} - U_{\text{final}}$. Equivalently, $\Delta U = U_{\text{final}} - U_{\text{initial}} = -W$.

Examples: Gravitational force (Earth pulling objects downward) and Spring force (stretched or compressed spring)

Non-Conservative Forces: If the work done by the force depends on the path taken.

Examples: Friction (solid and drag)

When you slide a book across a table, it eventually stops because friction converts its kinetic energy into heat. This lost energy cannot be fully recovered.

That is why friction is a non-conservative force.

Reflect on the following:

- If there were no friction, would a moving object ever stop?
- Why do pendulums slowly stop after some time?
- Why do machines require lubrication?

Quick Check

1. Define a conservative force with one example.
2. Why is gravitational force called a conservative force?
3. Why is friction called a non-conservative force?
4. What happens to energy when a non-conservative force acts on an object?
5. If there were no friction on Earth, how would motion be different? Explain.

5.2 Potential Energy of a Spring

Activity 5.2:

Collect the following items: A spring, a stand, a weight hanger, slotted weights, a ruler.

1. Suspend a spring vertically from a rigid support.
2. Attach a weight hanger to the free end of the spring and note the initial length of the spring.
3. Add a known weight to the hanger and measure the extension produced in the spring.
4. Increase the weight gradually and note the corresponding extension each time.
5. Repeat the experiment using springs made of different materials or thickness.

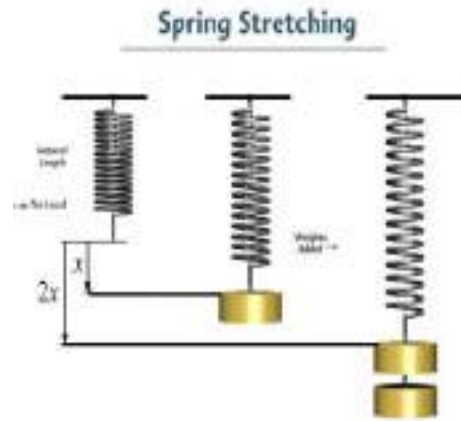

Observation:

- As more weight is added, the extension of the spring increases.

Different springs show different extensions for the same applied weight.

Conclusion:

The extension of a spring is directly proportional to the applied force (weight), provided the elastic limit is not exceeded. This relationship can be expressed as:

$$F = kx$$

where

F = applied force,

x = extension produced,

k = spring constant, which depends on the nature of the spring.

This law is called Hooke's law and is mathematically stated as $F = -kx$. The negative sign indicates the force is a restoring force acting against the direction of displacement (elongation or compression), aiming to return the spring to its original length.

Its unit is N m^{-1} . The spring is said to be stiff if k is large and soft if k is small.

Derivation

- The spring obeys Hooke's Law

$$F \propto x$$

$$F = kx$$

Prepare a graph between Force and extension in the spring with the help of data observed in the activity by taking

- X-axis → Extension (m or cm)
- Y-axis → Force (N)

Observation Table

These values give a straight-line graph passing through origin.

Sample Values for $k = 100 \text{ N/m}$

Force (F) in N	Extension (x) (in cm)	Extension (x) (in m)
0	0 cm	0 m
20	20 cm	0.2 m
40	40 cm	0.40 m
60	60 cm	0.60 m
80	80 cm	0.80 m
100	100 cm	1 m

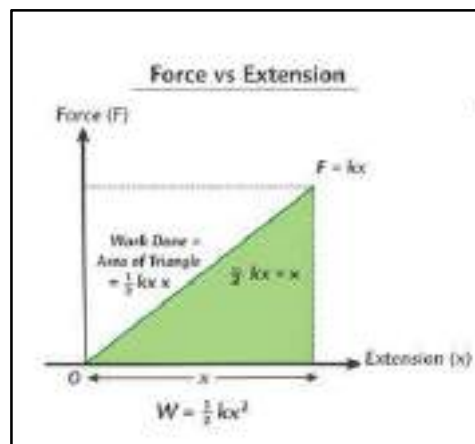

Calculation of Average Force:

For a spring stretched from 0 to maximum force:

$$\text{Average Force} = \frac{F_{\text{initial}} + F_{\text{final}}}{2}$$

When the spring is stretched gradually from zero extension to a maximum extension x , the force acting on it does not remain constant.

- At the beginning, force = 0
- At extension x , force = kx

So, the average force (spring force changes linearly from 0 to maximum as extension increases.) acting on the spring is given by:

$$F_{average} = \frac{0 + kx}{2} = \frac{kx}{2}$$

Work done in stretching the spring = Average force × Extension

$$W = \frac{kx}{2} \times x = \frac{1}{2}kx^2$$

Conclusion

The work done in stretching the spring is stored in it as elastic potential energy.

$$U = \frac{1}{2}kx^2$$

Example: A spring obeys Hooke's law with a spring constant of 30 N m^{-1} . If a force of 100 N is applied to the spring, calculate the extension produced in the spring. The Force-extension graph of a spring of spring constant 100 N m^{-1} is given in figure:

- Using the graph, determine the work done in stretching the spring from 2 cm to 6 cm .
- If the spring is released from the stretched position of 6 cm , calculate the maximum speed of a body of mass 0.5 kg attached to the spring, assuming no loss of energy.

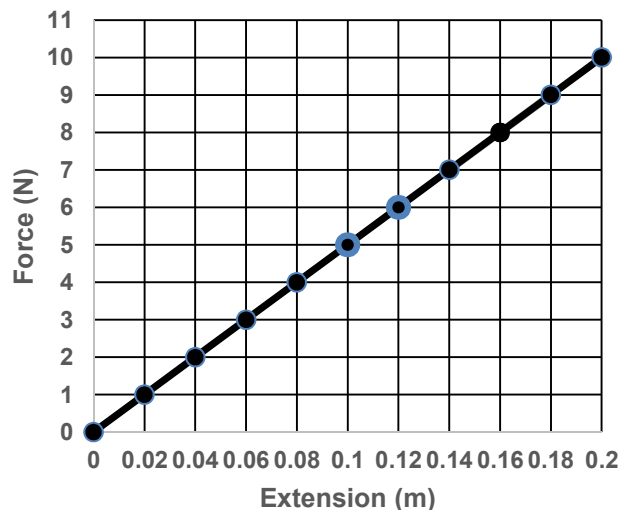

Solution:

- Work done = area under force–extension graph

$$W = \frac{1}{2}k(x_2^2 - x_1^2)$$

$$W = \frac{1}{2} \times 100 \times (0.06^2 - 0.02^2)$$

$$W = 50 \times (0.0036 - 0.0004)$$

$$W = 50 \times 0.0032 = 0.16 \text{ J}$$

(b) $k = 100 \text{ N/m}$, $x = 0.06 \text{ m}$. Elastic PE = $\frac{1}{2} \times 100 \times 0.06^2 = 0.18 \text{ J}$. At maximum speed, all PE converts to KE: $0.18 = \frac{1}{2} \times 0.5 \times v^2$, so $v^2 = 0.72$, $v \approx 0.85 \text{ m/s}$.

Check Your Understanding

- 1) Explain the conversion of potential energy to kinetic energy when a ball is thrown upward.
- 2) Why is gravitational potential energy considered a conservative force?
- 3) Calculate the potential energy of a 5 kg object kept on the top of a 30m high building. (Considering potential energy to be zero at the base of the building.)
- 4) What is the increment in its potential energy?
- 5) A 10 kg weight is hung from a 5 m wire, causing it to stretch by 1 mm. Calculate the energy stored.
- 6) Calculate the work done by an external force to lift a 2 m long rod from a horizontal to a vertical position.

Structure Of Atom

6.1 Discovery of Subatomic Particles

You have learnt about the development of models of the structure of the atom. You would recall that in 1803, Dalton proposed that atoms are the smallest indivisible particles of matter. However, this idea could not explain the results of several experiments. For example, it was observed that substances like glass or ebonite, when rubbed with silk or fur, acquire electric charge. This and many other experiments on electrical discharge through gases showed that atoms are not indivisible. They are made up of smaller particles called subatomic particles.

J. J. Thomson, in 1897, discovered the electron as a constituent of the atom and confirmed that the atom is not the smallest particle of matter. He proposed the so-called plum-pudding model of the atom, in which electrons are embedded in a sphere of positive charge. This model was later shown to be incorrect by Rutherford, as it could not explain the results of the gold foil experiment. Rutherford then proposed a model in which electrons revolve around a small, positively charged nucleus. However, this model could not explain the stability of the atom. Thereafter, another model was proposed by Niels Bohr.

Here, you will learn about the discovery of the subatomic particles—electron, proton, and neutron—which contribute to our understanding of atomic structure. Before discussing these exploration we must recall a basic principle: like charges repel each other, while unlike charges attract each other.

6.1.1 Discovery of Electron

In the late nineteenth century, many scientists, including Michael Faraday, William Crookes, and others, studied electrical discharge in partially evacuated tubes known as cathode ray discharge tubes. J.J Thomson carried out experiments by taking gases at low pressure in discharge tube which is a long glass tube in which two metal plates connected to oppositely charged poles of battery (Fig 1)

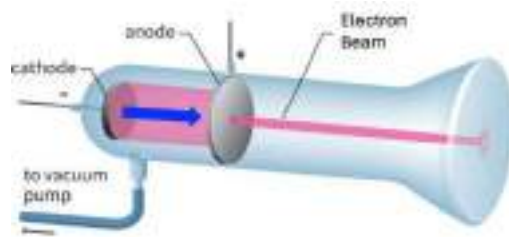

Fig. 6.1: A schematic representation of cathode ray tube showing the cathode rays going from the cathode to anode in a straight line

When a sufficiently high voltage is applied across the electrodes, rays are observed to travel from the negatively charged electrode (cathode) towards the positively charged electrode (anode). (Fig 2)

These are called cathode rays. The presence of these rays can be detected by allowing them to pass through a hole in the anode and strike at screen coated with a special material placed behind it. A bright spot is observed on the screen, indicating that the rays travel in straight lines.

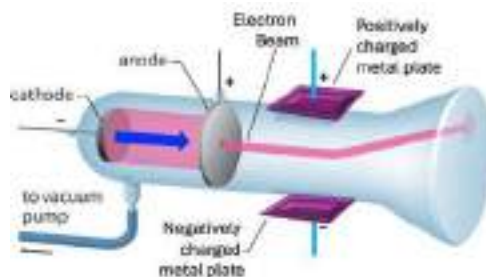

Fig.6.2: A schematic representation of the deflection of cathode rays to positive plate of the applied electric field.

Further to determine the nature of these rays, Thomson carried out experiments by applying electric and magnetic fields in the path of the rays. He observed that the rays were deflected towards the positively charged plate.

This showed that the particles in the rays carry negative charge on further experimentation. Thomson concluded that cathode rays consist of tiny negatively charged particles, later called electrons.

When these experiments were repeated using different gases (such as hydrogen, nitrogen, neon, etc.) and different electrode materials, it was found that the properties of cathode rays remained unchanged. This showed that electrons are present in all atoms.

The main characteristics of cathode rays are as follows:

- They originate from the cathode and move towards the anode.
- They are not visible themselves but produce bright spot when they strike certain materials.
- They travel in straight lines in the absence of external fields.
- They are deflected by electric and magnetic fields in such a way that indicates them to be negatively charged.
- Their properties do not depend on the nature of the gas or the electrode material.

Thus, electrons are a fundamental constituent of all atoms.

6.1.2 Discovery of Protons

After the discovery of the electron, it was realised that since electrons are negatively charged, atoms must also contain positive charge to maintain electrical neutrality.

Eugen Goldstein, in 1886, performed experiments using a discharge tube similar to that used for cathode rays, but with a cathode having holes in it (perforated cathode). When high voltage was applied, a faint glow was observed behind the cathode. The rays responsible for this glow passed through the holes (or canals) in the cathode and were therefore called canal rays.

Further studies showed that these rays were deflected towards the negatively charged plate in electric and magnetic fields, indicating that they consist of positively charged particles.

However, it is important to note that canal rays are not made up of a single type of particle. They consist of positively charged ions of the gas present in the tube. Therefore, their properties depend on the nature of the gas used.

When hydrogen gas was used in the discharge tube, the positively charged particles obtained were the lightest known and were identified as hydrogen ions (H^+). These particles were later recognised as protons. The proton was finally established as a fundamental particle by Rutherford in 1919.

The main characteristics of canal rays are:

- They are positively charged.
- Their behaviour in electric and magnetic fields is opposite to that of electrons.
- Their properties depend on the nature of the gas present.
- The lightest positive particle was obtained from hydrogen and is called the proton.

6.1.3 Discovery of Neutrons

Once electrons and protons were known, it appeared that the structure of the atom was understood. However, another problem arose when atomic masses were measured. The mass of atoms was found to be greater than the sum of the masses of their protons and electrons. For example, helium contains two protons, yet its mass is about four times that of hydrogen. This indicated the possibility of the presence of another particle contributing to the mass of the atom.

It was proposed that there must be a neutral particle present in the atom. This particle was discovered by James Chadwick in 1932. He bombarded a thin sheet of beryllium with alpha particles and observed the emission of powerful neutral

radiation. This radiation consisted of particles having no charge and a mass nearly equal to that of the proton. These particles were called neutrons.

Neutrons are present in the nuclei of almost all atoms. The most common isotope of hydrogen that does not contain a neutron is protium (${}_1\text{H}^1$) but its heavier isotopes Deuterium (${}_1\text{H}^2$) and Tritium (${}_1\text{H}^3$) contains neutrons.

Thus, the presence of neutrons explains the mass of atoms. For example, helium contains two protons and two neutrons, which accounts for its mass being approximately four times that of hydrogen.

Chadwick was awarded the Nobel Prize in Physics in 1935 for the discovery of the Subatomic particle neutron.

From these discoveries, it became clear that atoms are composed of three subatomic particles:

- Electrons (negative charge)
- Protons (positive charge)
- Neutrons (no charge)

These particles together determine the structure and properties of atoms.

Quick Check:

1. Why do cathode rays bend towards the positive plate?
2. What conclusion did Thomson draw from using different gases in discharge tubes?
3. Why are canal rays different from cathode rays in nature?
4. Why was the discovery of neutron necessary?
5. In a cathode ray experiment, it was observed that the rays bend towards a positively charged plate. What can we conclude about the nature of these rays?
6. In a discharge tube experiment, the gas is changed from hydrogen to neon, but the behaviour of cathode rays remains unchanged. What does this observation tell us about electrons?
7. If cathode rays were neutral instead of being negatively charged, how would their behaviour differ in an electric field?
8. In an experiment with canal rays, different gases are used and different masses of particles are observed. What conclusion can be drawn about the nature of canal rays?

9. Why did scientists feel the need to propose the existence of neutral particles even after discovering electrons and protons? Explain using the example of helium.
10. In Chadwick's experiment, the emitted particles were not deflected by electric or magnetic fields. What does this observation indicate about the nature of these particles?

6.2. Spectrum

When white light passes through a glass prism, what do we observe? We see a rainbow, that consists of a continuous spread of many colours from violet to red (VIBGYOR). Such a spread is called a **continuous spectrum** in which the colours are present without any gap.



Fig 6.3 Continuous Spectrum

Now, suppose we take a sodium vapour lamp, which you would have seen at street lights or in parks, and pass the 'yellow light' given out by it, through a prism. We find that we do not get all the colours but only a few bright coloured lines. Two of these are intense yellow lines. We may do a similar experiment with mercury vapour lamp and observe another set of distinct lines. Such a spectrum that contains distinct lines is called a **line spectrum**.



Fig 6.4 (a) Sodium vapour lamp



Fig 6.4 (b) Lines Spectrum of Sodium

Line spectrum means only specific radiation are emitted, not all. It is important to know that the line spectrum is characteristic of the element causing it. This fact is used to identify elements present in stars by studying their spectra. Even without going to the star, we can know what it is made of.

6.3 Line Spectrum of Hydrogen

Now, when the radiation from a discharge tube containing hydrogen gas in it is passed through a prism, it also gives line spectrum called **hydrogen atom spectrum**.

The Spectral lines for atomic hydrogen are:

Series	n_i	n_f
Lyman	1	2,3_-----
Balmer	2	3,4_-----
Paschen	3	4,5_-----
Brackett	4	5,6_-----
Pfund	5	6,7_-----

The energies of the distinct spectral lines observed in hydrogen atom spectrum could be expressed empirically in terms of mathematical expressions involving two sets of integers. This equation is known as Rydberg Equation.

$$\Delta E = R_E Z^2 \left(\frac{1}{n_f^2} - \frac{1}{n_i^2} \right)$$

$$R_E = 109,677 \text{ cm}^{-1}$$

Where, R_E is the Rydberg constant expressed in terms of energy and Z is the atomic number. These empirical formulas worked very well but could not be explained until Bohr's model came.

6.4 Limitation of Rutherford Model of Atom

- Rutherford could not explain stability as the electron continuously loses energy when it moves around the nucleus.
- As the electron in the atom is allowed to have continuous energies, therefore the emitted radiation is expected to give a continuous set of radiation. However, we observe a line spectrum. Therefore, we say that Rutherford's model fails to explain the existence of line spectrum of hydrogen.

6.5 Bohr's model

Neils Bohr, a student of Rutherford, in 1913 proposed his model for an atom. He combined Rutherford's nuclear model with the new quantum idea introduced by Max Planck. He made two revolutionary assumptions which are as below:

- Electrons can move only in certain allowed circular orbits without radiating energy. That is, they have a fixed energy as long as they are in a given orbit.
- The radiation is emitted or absorbed only when an electron jumps from one allowed orbit to another,

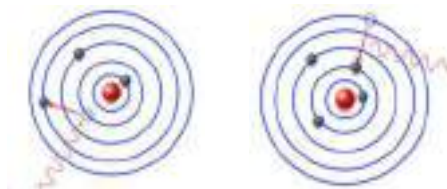

Fig 6.5:Energy change is electron jump

6.5.1 Achievement of Bohr Model

“When an electron jumps from an orbit of higher energy to that of a lower energy it releases energy in the form of radiation. The amount of energy released depends on the difference in the energies of the two levels. Since the orbits of only certain energies exist, only of fixed quantity energy differences are possible. Therefore, we get a line spectrum. Bohr’s model could explain the observed line spectrum of hydrogen fairly well.

6.5.2 Limitations of Bohr’s model

Bohr model was unable to explain:

- Finer details (that is closely spaced lines) of hydrogen atom spectrum observed by sophisticated spectroscopic techniques.
- The spectrum of atom other than hydrogen.
- The splitting of spectral lines in presence of magnetic field (Zeeman effect) or an electric field (Stark’s effect).

6.6 Check Your Understanding

1. The hydrogen spectrum consists of only a few sharp spectral lines instead of a continuous spectrum. What information does it provide about the energy of electrons in an atom.
2. Explain why would Rutherford’s model predict a continuous spectrum rather than a line spectrum.
3. A discharge tube filled with an unknown gas produces a line spectrum identical to hydrogen. What can you conclude about the gas? Give reason.
4. If electrons in an atom were allowed to have a continuous set of energy values, what kind of spectrum would you expect? Why is this not observed?
5. “Bohr’s model solved all problems of atomic structure.” Comment.
6. How does the concept of fixed energy levels explain the stability of atoms?

7. Why do different elements produce different line spectra? Give a conceptual explanation.
 8. Explain why Bohr's model works well for hydrogen but not for multi-electron atoms.
 9. State two limitations of Rutherford's model.
 10. Rutherford's model explained the structure of the atom but failed to explain atomic stability and spectra. Discuss.
 11. What was the main drawback of Rutherford's model regarding electron motion? What assumption was made by Bohr to overcome this problem.
 12. How does Bohr's model explain line spectrum of hydrogen?
 13. Outline the limitations of Bohr's model.
 14. Define line spectrum and continuous spectrum with one example each.
 15. Write two main postulates of Bohr's model.
 16. What is meant by fine structure in hydrogen spectrum?
 17. What is the significance of Rydberg equation?
-

Chemical Bonding

7.1 Octet Rule

You have learnt that the atoms having eight electrons in its valence shell are stable. The atoms other than hydrogen tends to form bonds until it is surrounded by eight valence electrons. They do so by gaining, losing or sharing electrons. It is called **Octet rule** and is quite useful in describing the formation of simple molecules. It is important to note that the octet rule is just a guiding principle and not a law. In case of hydrogen, the valence shell attains the electron configuration of helium, i.e., a total of two electrons.

7.1.1 Lewis Approach

Lewis Symbol :- The Valance electron of an atom in terms of dot is written around the atom.

For Example:

Fluorine (F=9) Electronic configuration=2,7

Valence electron=7

Hence is represented as:

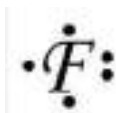

Bonding in molecule:

Duing bonding the valance electrons are written around the atoms and then electrons are shared in such a way so as to complete the octet of each atom.

For Example the Lewis formula for Hydrogen Fluoride is

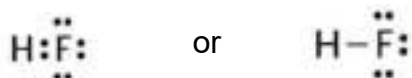

Here the pair of dots (representing electrons) placed between the symbols of the combining atoms represent the bonding electrons. The remaining dots represent the non-bonding electrons. As the name suggests, the non-bonding electrons do not contribute to the bonding. You may note that the hydrogen atom in this molecule has only two electrons (a duplet) around it. The line here indicates the bond between hydrogen and fluorine atom.

7.1.2 Exceptions of Octet Rule

Many stable molecules do not follow the octet rule. These are called exceptions to the octet rule. Let us discuss about these exceptions.

Molecules with incomplete octets

In case of some elements the valence shell has less than four valence electrons. In these cases, their atoms cannot form four bonds to complete the octet. Also, these do not have sufficient lone pairs that can complete the octet. As a result, the octet remains incomplete in such cases. For example, in case of lithium, beryllium and boron there are only 1, 2 and 3 valence electrons respectively. Therefore, these can form 1, 2 and 3 bonds respectively. In such cases the central atom would have 2, 4 and 6 electrons respectively on forming the molecule. These represent molecules which do not complete the octet and yet are stable. One common example is that of boron trifluoride. In this molecule, one boron atom makes bonds with three fluorine atoms and is represented as



The lines here indicate the bond between boron and fluorine atom.

Molecules with expanded octets

Another exception to the octet rule is observed in the formation of molecules having more than eight valence electrons around central atom. Such molecules are formed by the atoms of the elements having more than four electrons in their valence shell. For example, in case of sulfur hexafluoride one atom of sulphur combines with six atoms of fluorine. The Central sulphur atom has 12 electrons in its valence shell representing an expanded octet. We can represent its structure as



You will learn about the formation of such compounds in higher classes.

Molecules with odd number of electrons

Certain molecules have an odd number of electrons. For example, an atom of nitrogen (having 5 valence electrons) makes two bonds with an atom of oxygen (having six valence electrons) to form a molecule of NO. It has a total of 11 valence electrons, five from N and six from O atom. The Lewis structure for this molecule can be represented as

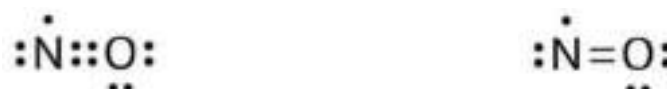

The two lines here indicate two bonds. Whenever there are odd number of electrons in a molecule then at least one atom would have an incomplete octet. Secondly in such a molecule there would always be an unpaired electron.

Quick Check

1. What is meant by the octet rule?
2. Why does hydrogen not follow the octet rule?
3. Give one example each of the molecule with
 - a) incomplete octet
 - b) expanded octet
 - c) an odd electron
4. Why can boron form compounds with only six electrons around it?
5. What is meant by a duplet configuration?
6. Why is NO considered an exception to the octet rule?
7. Draw the Lewis dot structure of BF_3 and explain why boron does not complete its octet.
8. Assertion: SF_6 violates the octet rule.
Reason: Sulphur can accommodate more than eight electrons.
 - A. Assertion and reason, both are correct and reason is the correct explanation of the assertion.
 - B. Assertion and reason, both are correct but reason is not the correct explanation of the assertion.
 - C. Assertion is correct but reason is a wrong statement.
 - D. Assertion is wrong but the reason is a correct statement.

7.2 Metallic Bonding

You all are familiar with metals like iron, copper, aluminium, and so on. They are hard, they can be beaten into sheets, drawn into wires, and they conduct electricity. You may be wondering how can we explain these properties of metals. We can explain these in terms of a simple model known as the electron sea model for metals. You have learnt about bonding in case of ionic and covalent compounds. In these, the atoms bind by transfer or sharing of electrons between specific atoms. The electron sea model, in fact, is a simple model for bonding in metals. It involves bonding between a very large number of atoms of the metal. Let us understand this model and learn how we can explain the properties of metals by using this model.

7.2.1 Electron Sea Model

A metal atom has a few electrons in its outermost shell. These outer electrons are not held very tightly by the nucleus. Because of this, when many metal atoms come together to form a solid, these outer electrons do not remain attached to any

one atom. Instead, they become delocalised and are free to move throughout the entire piece of metal.

You know that when an atom loses an electron it becomes a cation. In metals, the atoms can be thought of as forming positive metal ions arranged in a regular pattern. These ions form a kind of fixed structure. The free electrons move continuously and randomly in all directions around and between these ions. This collection of freely moving electrons is called a “sea of electrons”.

Thus, according to the electron sea model, a metal can be seen as a structure in which positive metal ions are fixed in place, and a “sea” of mobile electrons moves around them. This is why the model is called the electron sea model as shown in Fig.7.1.

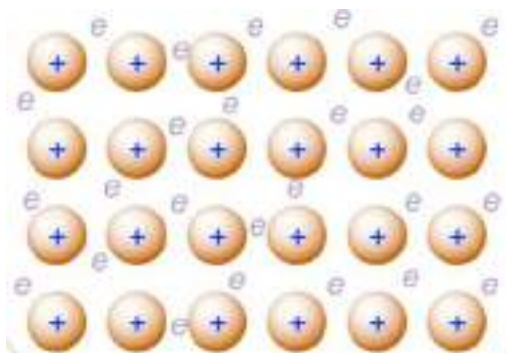

Fig. 7.1: Schematic representation of Electron sea model

These ions and electrons together form a stable structure. The attraction between the positive ions and the sea of electrons is what holds the metal together. This attraction is called **metallic bonding**. So, we can say that metallic bonding is the force of attraction between positive metal ions and the sea of electrons. It is important to note that unlike covalent bonds, metallic bonds are not localised. The electrons are shared by all the atoms collectively, forming a non-directional bond that can adjust to shifting positions of the metal ions.

7.2.1: Electron sea model and properties of metal

Now let us see how this simple electron sea model helps us to understand the properties of metals.

Electrical conductivity

Since electrons are free to move, when we apply an electric field across a metal, these electrons start moving in a particular direction. This movement of electrons is what we call electric current. That is why metals are good conductors of electricity.



Fig.7.2: Schematic representation of electrical conduction by metals in terms of electron sea model

Thermal conductivity

When one part of a metal is heated, the electrons in that region gain energy and start moving faster. As they move, they transfer this energy to other parts of the metal. At the same time, the metal ions also vibrate more and help in passing the heat along. In this way, heat spreads quickly. This is why metals are good conductors of heat.

Malleability and Ductility

You know that malleability refers to the ability of metals to be beaten into thin sheets. In the electron sea model, the positive metal ions can slide over one another without breaking the structure. This is possible because the electrons are not fixed; they continue to move and hold the ions together. So, even when layers of the metal ions shift, the metal does not break.

Similarly, you know that ductility refers to the ability of metals to be drawn into wires. When we stretch a metal, these metal ions slide past each other without breaking the non-directional metallic bonds, allowing the metal to stretch into wires. The free electrons help maintain the attraction between ions even when the shape changes.

You must remember that the electron sea model gives a simple picture and explains many basic properties of metals. The electrons are not completely lost as in ionic bonding; rather, they are shared collectively by all atoms in the metal. You will learn more detailed models of metallic bonding in your higher classes.

Check Your Understanding

1. What is meant by the term “electron sea” in metals?
2. What type of particles are in a fixed position in a metal according to the Electron sea model?
3. Define metallic bonding.
4. Why are metallic bonds called non-directional?

5. Name two properties of metals explained by the electron sea model.
6. Explain how the electron sea model accounts for electrical conductivity in metals.
7. How does the electron sea model explain thermal conductivity in metals?
8. Why can metals be beaten into thin sheets? Explain using the Electron sea model.
9. What is meant by ductility? How is it explained by the electron sea model?
10. How is metallic bonding different from covalent bonding?
11. Explain the structure of a metal according to the electron sea model.
12. If electrons in a metal were not free to move, which property would be most affected? Explain.
13. Explain why metals do not break when hammered but instead change shape.
14. Copper is used for electrical wiring, while rubber is not. Explain using the electron sea model.
15. Why are metals generally good conductors of heat as compared to non-metals?
19. Assertion (A): Metals are good conductors of electricity.
Reason (R): Metals contain free electrons that can move under an electric field.
 - A. Assertion and reason, both are correct and reason is the correct explanation of the assertion.
 - B. Assertion and reason, both are correct but reason is not the correct explanation of the assertion.
 - C. Assertion is correct but reason is a wrong statement.
 - D. Assertion is wrong but the reason is a correct statement.
20. Assertion (A): Metallic bonds are non-directional.
Reason (R): Electrons in metals are localised between two atoms.
 - A. Assertion and reason, both are correct and reason is the correct explanation of the assertion.
 - B. Assertion and reason, both are correct but reason is not the correct explanation of the assertion.
 - C. Assertion is correct but reason is a wrong statement.
 - D. Assertion is wrong but the reason is a correct statement.
21. Assertion (A): Metals are malleable.
Reason (R): Layers of metal ions can slide while electrons continue to hold them together.

- A. Assertion and reason, both are correct and reason is the correct explanation of the assertion.
- B. Assertion and reason, both are correct but reason is not the correct explanation of the assertion.
- C. Assertion is correct but reason is a wrong statement.
- D. Assertion is wrong but the reason is a correct statement.

Mixtures And Separation Of Mixtures

8.1 Chromatography

Chromatography was first developed by the **Russian botanist Mikhail Tswett in 1906** while studying plant pigments. He used this technique to separate the different coloured constituents of chlorophyll. This method was named **chromatography** components of chlorophyll. The name chromatography comes from the Greek words chroma (colour) and graphein (to write). The technique is used to **separate the mixtures into components, purification of compounds and also to test the purity of compounds.**

Principle: The technique is based on the difference in the rates at which the components move through a stationary medium under the influence of moving phase..

Application: Today, chromatography is widely used in chemistry, biology, and medicine to **identify and separate different substances in a mixture.**

Column Chromatography

Modern method for the separation of mixtures into its components. The selective removal of the components may be due to adsorption or partition process.

When a mobile phase is allowed to move over a stationary phase, the components of the mixture move by varying distances over the stationary phase because of different adsorption tendencies. In this case the stationary phase can be held on a cylindrical column of solid . hence it is called column chromatography.

Principle: It is based on the fact that different compounds are adsorbed on an adsorbent to different degrees

Procedure: In this technique, a long glass tube having a stop cock near the bottom, called a column is used. First a plug of cotton or glass wool is placed at the bottom of the column. Then it is filled with a solid material such as silica gel or alumina, which acts as the **stationary phase** (fixed in a place). The mixture to be separated is placed at the top of silica gel in the column, and then a little amount of glass wool is placed above the mixture. After this a suitable liquid solvent is poured from above and allowed to flow through the column under the influence of gravity. This is called an eluent or the **mobile phase** (which moves). The solvent coming out from the column is collected in different fractions. In this way, the components of the mixture get separated and are collected separately. Column chromatography is widely used in chemistry laboratories to purify compounds as well as to separate them from the mixtures.

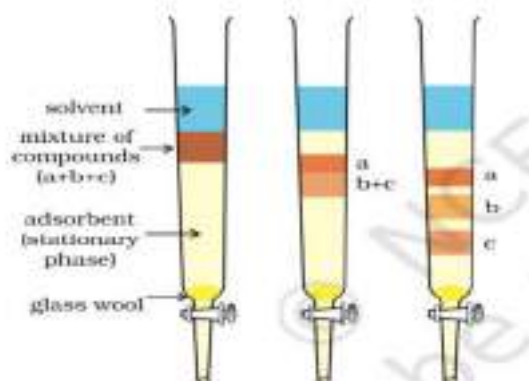

Fig 8.1: Column chromatography: Different stages of separation of components of a mixture.

Application: The method has been used:

- To separate blue and red dyes
- To separate and purify plant pigments

8.2.1 Fractional Distillation

This method is used for the purification of liquids which boil without decomposition and contain non volatile impurities.

Principle: Fractional Distillation is a technique to separate a mixture of two miscible liquids whose boiling points differ by less than 25⁰C shown in Fig. 8.2 (a).

In this process, the mixture of liquids is heated in a distillation flask which is fitted with a fractionating column before the condenser as shown in figure 8.2(b).

Fractionating Column: The fractionating column is a long tube provided with obstructions to the passage of vapours moving upwards and liquid moving downwards. It increases the cooling surface area.

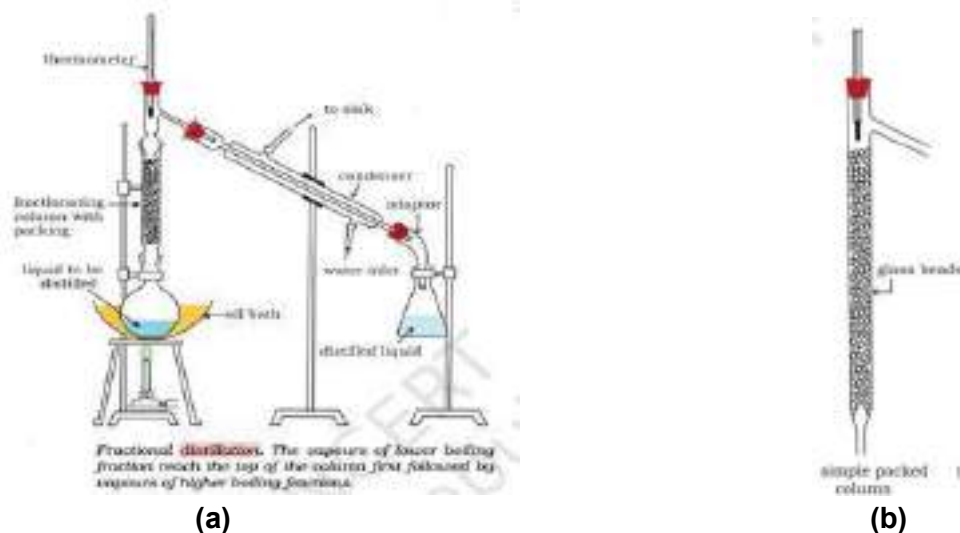

Fig 8.2: (a) Fractional distillation apparatus and (b) A sample fractional distillation column

Procedure: When the mixture is added to distillation flask and the flask is heated the vapours of more volatile liquid having low boiling point rises up in the fractionating column. Due to the obstruction in the fractionating column, some of the vapours condense and fall back in the column. Some of the condensing liquid in the fractionating column gets heat from the ascending vapours and re-vaporizes. As a result the vapours become richer in low boiling component. These rise up in the fractionating column and condense while passing through condenser and collected in the receiver. The same process will occur again and again. This repeated condensation and vaporization helps in better separation of the liquids. By carefully controlling the temperature, different liquids in the mixture can be separated one after another according to their increasing boiling points.

8.2.2 How is it different from simple distillation?

- In fractional distillation, a fractionating column is placed between the distillation flask and the condenser. The column provides many surfaces where repeated condensation and vaporization occur. This allows better separation of liquids whose boiling points are close to each other.
- Simple Distillation is used to separate miscible liquid which differ in boiling point by at least 25°C but in fractional distillation the boiling point differ by less than 25°C

8.2.3 Application

Crude oil is a complex mixture of many hydrocarbons with different boiling points. In a refinery, the crude oil is heated, and the vapours enter a tall fractionating column. As the vapours rise in the column, they cool and condense at different levels according to their boiling points. Different fractions are collected at different heights of the column as shown in the figure below along with the temperature range. The various important fractions used in our daily life or industry are:

- Petroleum gas (LPG, contains butane and propane)
- Petrol (gasoline)
- Kerosene
- Diesel
- Fuel oils
- Lubricating oil and heavy oils

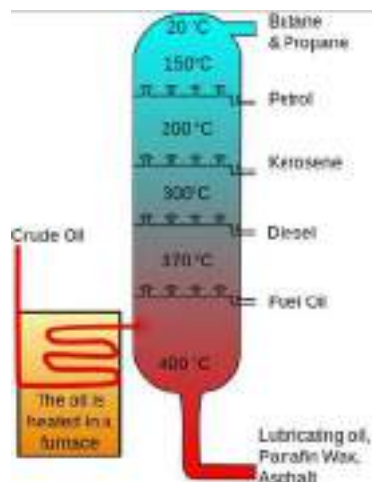

Fig 3: (a) Schematic representation of separation of different components of crude oil by fractional distillation

Questions

1. What is chromatography? Mention its two main phases.
2. Who discovered chromatography and in which year?
3. What is meant by stationary phase and mobile phase?
4. Name two common adsorbents used in column chromatography.
5. What is an eluent in column chromatography?
6. Why do different substances move at different speeds in column chromatography?
7. What is fractional distillation?
8. When is fractional distillation preferred over simple distillation?
9. What is the role of the fractionating column?
10. In column chromatography, a mixture of two compounds A and B is separated. A comes out first. What can you say about its interaction with the stationary phase?
11. A mixture of ethanol (b.p. 78°C) and water (b.p. 100°C) is to be separated. Which method will you use and why?
12. Explain why repeated condensation and vaporization improve separation in fractional distillation.
13. In a fractional distillation column, why does temperature decrease from bottom to top?
14. Why is simple distillation not suitable for separating liquids with close boiling points?
15. Assertion: In chromatography, separation occurs due to difference in boiling points.
Reason: Components move at different speeds in the column.
A. Assertion and reason, both are correct and reason is the correct explanation of the assertion.

- B. Assertion and reason, both are correct but reason is not the correct explanation of the assertion.
 - C. Assertion is correct but reason is a wrong statement.
 - D. Assertion is wrong but the reason is a correct statement.
16. Assertion: Fractional distillation gives better separation than simple distillation.
Reason: It involves repeated condensation and vaporization.
- A. Assertion and reason, both are correct and reason is the correct explanation of the assertion.
 - B. Assertion and reason, both are correct, but reason is not the correct explanation of the assertion.
 - C. Assertion is correct, but reason is a wrong statement.
 - D. Assertion is wrong, but the reason is a correct statement.
17. Difference in which property forms the basis for separating components in fractional distillation?
- A. Solubility
 - B. Boiling points
 - C. Particle size
 - D. Chemical reactivity
18. What is the main purpose of the "fractionating column" in fractional distillation?
- A. To heat the mixture faster.
 - B. To cool the vapours at fast rate.
 - C. To provide more surface area for vapours.
 - D. To let the vapours of two liquids mix properly
19. In column chromatography, the solid substance that is filled in the column is called the:
- A. Mobile phase
 - B. Solvent
 - C. Stationary phase
 - D. Mixture
20. That component of a mixture moves down the column at a faster rate which is
- A. most attracted to the stationary phase.
 - B. having the highest boiling point.
 - C. The one most soluble in the mobile phase (solvent)
 - D. The one with the largest particle

Microscope and Microscopy

9.1. What is a Microscope?

You have read in Grade 8 that a special instrument called the **microscope** (*micro* – small; + *skopion* - "means of viewing") is required to observe tiny living organisms or their parts which cannot be seen through naked eyes by magnifying them. With a microscope, you can see small specimens such as onion cells, cheek cells, bacteria and even dust particles etc. It helps doctors to see germs and study cells in living organisms.

What do we call the ability of a human eye to see two very close objects as separate and distinct? Imagine two tiny dots drawn on a piece of paper. As the dots are moved closer, there comes a point at which they can no longer appear as separate. When viewed from about 25 cm (the near point of the eye), two points separated by about 0.1 mm (100 μm) can be observed as distinct, otherwise, they appear as a single point. This defines the **limit of resolution** of the human eye.

A cell is generally too tiny to be observed by an unaided eye. This raises an important question - how do cell biologists study the structure and functioning of cells, which are much smaller than the limit of resolution of the human eye?

When Robert Hooke observed 'cork' under the microscope developed by him in 1665. He examined thin slices of bark of an oak tree and observed tiny hexagonal box-like spaces just like the patterns of honeycomb and called them **cells**. Around the same time, Antony van Leeuwenhoek made tiny, powerful lenses and saw "animalcules" – what we now know as bacteria and protozoa. Those simple lenses opened the door to a completely new world.

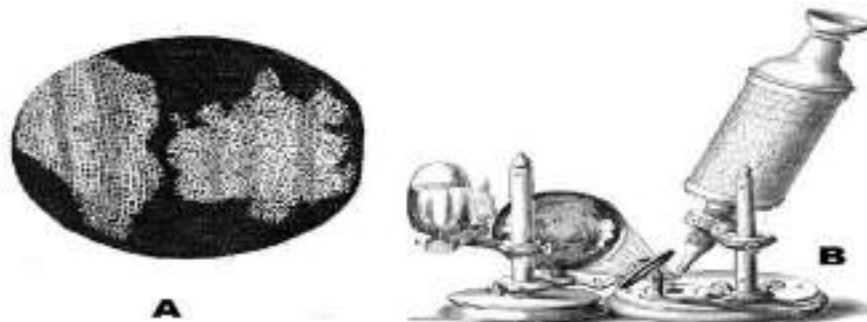

Figure 9.1: A. Drawings of Cork cells as published in the 'Micrographia'; B. Microscope developed by Robert Hooke,

Activity 9.1: Let us think and write:

If you could shrink yourself and travel inside a leaf, what would you see? Write 3 – 4 lines imagining that journey.

9.2. A Quick historical Journey of Microscopes

Let us walk through time and see how microscopes evolved:

- **13th–15th century:** Simple magnifying glasses used by spectacle makers.
- **1590 - Hans and Zacharias Janssen:** A Dutch father-and-son duo of spectacle makers developed an early compound microscope by combining two lenses within a single tube.
- **1665 – Robert Hooke:** Coined the term ‘cell’ for empty, hexagonal, box-like structures by examining the cork of an oak tree under the microscope developed by him. He published his findings in a book called “Micrographia”.
- **1670s – Antony van Leeuwenhoek:** He worked with a simple, single-lens microscope capable of magnifying up to about 300 times, which allowed him to observe tiny living organisms he called “animalcules,” including bacteria and protozoa. He was the first to study living microorganisms and is widely regarded as the *Father of Microscopy*.
- **1878 Ernst Abbe:** Postulated a mathematical theory linking resolution to the wavelength.
- **19th–20th century:** Better lenses and illumination improved the compound light microscope.
- **1930s onwards: Electron microscopes** (TEM and SEM) were invented where viruses, cell organelles and cell surfaces could be observed.
- **1938 Ernst Ruska:** developed the first electron microscope, which operated on the principle using electrons as the illumination source (instead of light) that provides shorter wavelengths and thereby significantly enhancing the resolving power.
- **1953: Frits Zernike** received the Nobel Prize in Physics for inventing and demonstrating the phase-contrast microscope.

Activity 9.2: A Timeline Strip

Draw a horizontal line. Mark at least 5 important dates in microscopy and add a tiny sketch or symbol for each (e.g., cork cells, bacteria, electron beam etc.).

9.3. How Does a Microscope Work?

An important parameter in microscopy is the **resolution**, **contrast** and **magnification** of the object that is viewed under the lens, which makes it appear several times larger to the human eye. The operating principle varies with the type of microscope, which can be broadly classified by whether they use multiple lenses or electron beams. In each case, a system of lenses or electromagnetic fields is used to produce an enlarged, detailed image of a specimen that cannot be clearly seen with the naked eye.

9.3.1 Types of Light microscope

Light (Optical) microscopes rely on visible light and glass lenses to enlarge and view specimens.

Basic Classification -

- **A simple microscope** utilizes a single lens to magnify an object, similar to how a magnifying glass works. For example, dissecting microscope is used for 3D viewing of small objects.
- **Compound Microscope:** Most commonly used laboratory microscope utilizes at least two sets of lenses - the objective lens (near the specimen) and the eyepiece (ocular lens) - to achieve high magnification.
- **Advanced optical microscopes**

Beyond the standard compound microscope, a diverse family of advanced light microscopes exists—such as Phase-Contrast and Fluorescence, each using unique optical technique to reveal hidden cellular secrets that would otherwise remain invisible to the naked eyes. **Fluorescence microscopy** uses high-intensity light to excite specialized dyes in a specimen, causing specific cellular structures to glow brilliantly against a dark background like stars in the night sky. **Phase-Contrast** microscopy is used for viewing **living cells** in their natural state because it enhances contrast without the need for chemical stains that would otherwise kill the specimen.

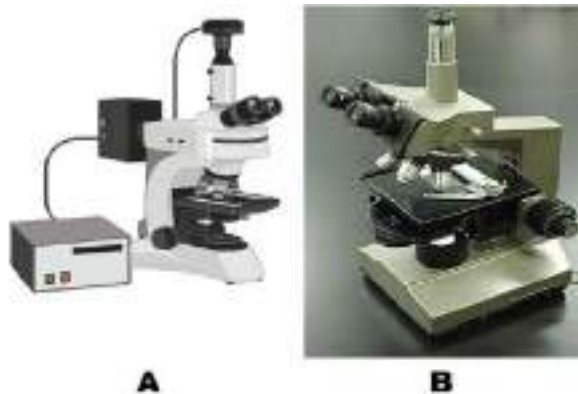

Figure 9.2: A. Fluorescence microscope; B. Phase contrast microscope

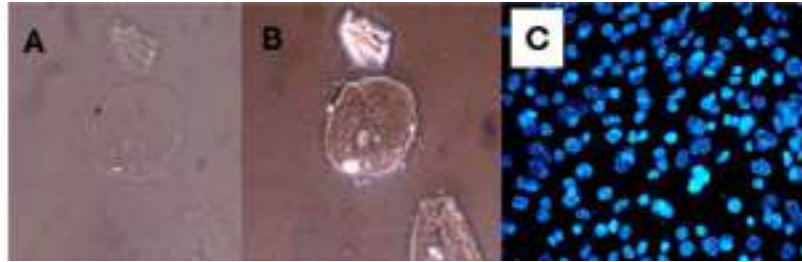

Figure 9.3: Cells imaged with – A. Traditional optical microscope (Mag. 40X) B. Phase-contrast microscope (Mag. 40X) and C. Fluorescence microscope (Mag. 20X)

9.3.2 Parts of a Compound microscope

Core Components and their Roles

1. **Light Source**; Provides illumination (LED or halogen lamp).
2. **Condenser Lens**: Focuses light onto the specimen to optimize numerical aperture and contrast.
3. **Specimen Stage**: Holds the slide containing the specimen.
4. **Objective Lens**: The primary magnifying lens (e.g., 4X, 10X, 40X, 100X). It forms an enlarged, inverted image of the specimen that is real in nature.
5. **Eyepiece (Ocular Lens)**: It enhances the magnification of the image already produced by the objective lens.

Activity 9.3: Let us examine a compound microscope

Key parts include eyepiece, objectives, nosepiece, stage with clips, coarse/ fine focus, condenser, iris diaphragm, illuminator, arm, and base

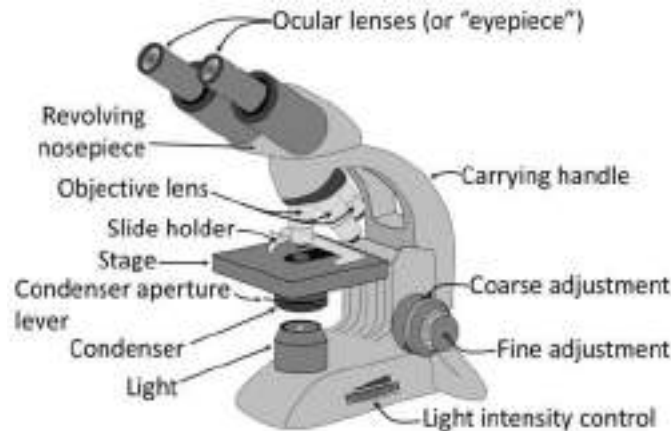

Figure 9.4: Light (compound) microscope

- **Objective lenses**: Main magnifying lenses (with different magnification power (X) – 4, 10, 15, 20, 40 etc.) close to the slide. These form a real, magnified image of the object.

- **Eyepiece (ocular lens):** Where you place your eye. It acts like a magnifying glass for the image formed by the objective. Together, these lenses produce a greatly enlarged image for your eye.
- **Body tube:** A hollow tube which has the eye piece and objective fitted on its two ends.
- **Revolving nosepiece:** Holds objectives and allows you to switch between them.
- **Stage and clips/ mechanical stage:** Platform to hold the slide in place.
- **Condenser Lens:** Consists of convex lens to focus and concentrate the light on specimen to optimize numerical aperture and contrast.
- **Substage diaphragm:** Controls the amount of light transmitted on specimen
- **Coarse adjustment knob:** Big knob for rough focusing (low power).
- **Fine adjustment knob:** Small knob for sharp focus (high power).
- **Arm and base:** Support; always hold microscope by the arm and support the base.
- **Light source/ mirror:** Provides light that passes through specimen/reflects light.

9.3.3 Light Microscope – working

Light changes direction when it passes through glass. You have earlier learnt in Grade 8 that a **convex lens** (converging lens) bends light rays to meet at a point. When we place a tiny object near such a lens, the lens forms a larger, inverted image. Light microscopes function by using refraction—the bending of light as it moves between different media due to changes in speed—along with reflection to direct and focus light rays. The objective lens, which has a short focal length, first creates a real and inverted image of the specimen placed just outside its focal point. This image then becomes the input for the eyepiece, which has a longer focal length and further enlarges it, producing the final upright, highly magnified virtual image.

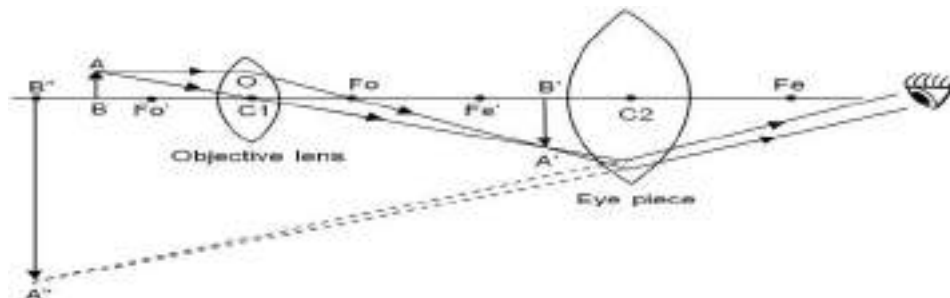

Figure 9.5: Ray diagram of compound microscope

9.4. Microscopy Skills

9.4.1 Slide Preparation and Focusing (temporary mount)

You have already learnt the method for preparing a temporary mount of an onion peel; using a similar approach, let us now create a few more temporary mounts.

Activity 9.4: Let us prepare, observe and compare leaf peels of monocot and dicot leaves:

Take peels from both upper and lower epidermis of a monocot leaf (*Rhoeo/ maize/ lily*) and a dicot leaf (*Bryophyllum/ petunia/ balsam*). Prepare their temporary mounts. Observe them under microscope, compare their structure and draw labelled diagrams. Record similarities and differences, if any.

Now correlate the points noted by you in activity 9.1 with your observations.

S. No.	Feature	Monocot leaf		Dicot leaf	
		Name of source plant.....		Name of source plant.....	
1.	Shape of epidermal cells				
2.	Pattern of epidermal cells				
3.	Shape of Guard cells				
4.	Distribution of stomata				
5.	Any other observation				

9.4.2 Permanent Slides

We have already learnt how to prepare temporary mounts. These are useful only for a short time because the drop of water slowly dries up and the living cells start shrinking, and dying. If you leave a temporary mount of an onion peel for a few hours, you will notice air bubbles, crystals of the dried stain, and distorted cell shapes instead of fresh, clear cells.

Now think, what if we want to keep a well prepared slide of onion cells or cheek cells safe so that many future batches of students in your school can observe it? For this purpose, biologists make **permanent mounts**. The slides stored carefully in slide boxes in your laboratory are usually permanent slides that have been prepared using a special technique and preserved for years.

In a **permanent mount**, the specimen is first fixed (to kill and preserve its structure), then stained, dehydrated, and finally sealed in a special mounting medium such as Canada balsam or DPX under a coverslip. This prevents the

specimen from drying, rotting, or being attacked by microorganisms. Once prepared properly, a permanent slide can be stored in the laboratory and used repeatedly without losing clarity of cells when seen under the microscope.

Activity 9.5: Let us observe permanent slides of leaf peel of a monocot and dicot leaf

Observe a permanent slide of leaf peel of monocot and dicot leaf and compare it with the temporary mount prepared by you.

Do you find any difference in the clarity of the slides? Notice the cell walls and guard cells in the fresh temporary mount and the stained permanent mount of the dicot peel? Does the clarity of cell walls and guard cell differ? Identify two common anatomical differences in leaf peels that remain consistent in temporary and permanent mount.

9.4.3 By what factor is the image larger than the actual object?

When you look at a diagram of a cell or a tiny insect in your book, it often appears huge on the page, now you know that it might be smaller than a grain of sand. Further, when you observed onion peel cells under the microscope you would have noticed the difference in the size of image when we switch from low power to high power objective lens.

How do you know *exactly* how many times bigger you are seeing the image? We can find out by finding the magnification of objective and eye piece. Magnification is represented by the symbol X , which is read as “times,” for example, 10X means “magnified ten times.”

Magnification of a microscope: $M = m_o \times m_e$
Where m_o = magnification of objective, m_e = magnification of eyepiece.

Example:

- 10X eyepiece and 40x objective $\rightarrow M = 10 \times 40 = 400$.
- Real size = image size / total magnification

Let us find out:

1. If a cell measures 5 mm on 100X image, calculate its actual size.
2. If you use a 15X eyepiece and 10X objective, what will be the total magnification?
3. If 4 cells fit across a 0.8 mm field of view, what will be the approximate size of one cell?

9.5. Types of Microscopes

All microscopes do the same basic function – they magnify small objects – but they do it in different ways and to different depths. Magnification and resolution are core concepts in microscopy that define the imaging capabilities of a microscope. Different microscopes have different magnification powers and resolution ranges; the size of the specimen and purpose of observation determines which microscope can be used to view the specimen effectively.

9.5.1 Magnification vs. Resolution – Big vs. Sharp image

Generally, students think: “More magnification is always better.” Not always true!

- **Magnification:** Magnification is the factor by which a microscope enlarges the image of a specimen relative to its actual size (e.g., 400x).
- **Resolution:** Resolution is the smallest distance between two very close points in a specimen to clearly distinguish them as separate and not merged into a single image. It is often expressed as a unit of length e.g. 0.2 μm for light microscopes. Higher resolution reveals fine details and gives a sharp image. **Resolving power** is the capacity of the microscope to clearly identify two very closely placed points as separate points. It is expressed as the reciprocal of resolution (smaller resolution means higher resolving power).

The **resolution** of human eye and some microscopes is given below:

Instrument	Resolution (in metre)
Human eye	$\sim 1 \times 10^{-4} \text{ m}$ ($\approx 0.1 \text{ mm}$)
Light microscope	$\sim 2 \times 10^{-7} \text{ m}$ ($\approx 0.2 \mu\text{m}$)
Electron microscope	$\sim 2 \times 10^{-10} \text{ m}$ ($\approx 0.2 \text{ nm}$)

Let's know more about the units of length used in microscopy:
1 cm = 10 mm
1 mm = 1,000 μm (micrometres)
1 μm = 1,000 nm (nanometres)

9.5.2 Light (Compound) Microscope

This is the microscope you generally use in school laboratories.

- It uses **visible light** and **glass lenses**.
- Its magnification is usually up to about 1000x.
- Its resolution (smallest detail you can see clearly) is about 0.2 μm .
- It can be used to observe living cells, like moving protozoa or cheek cells.

9.5.3. Electron Microscopes

- Electron microscopes operate with electron beams that have extremely short wavelengths (about 0.005 nm compared to 550 nm for visible light). These electrons are accelerated in a vacuum and directed using magnetic lenses.
- Electrons also behave like waves, but with a **much shorter wavelength** than visible light. A shorter wavelength gives better resolution.
- Electromagnets act as “lenses” to focus on the electron beam.
- Source of electron beam (Tungsten filament).

9.5.3.1 Transmission Electron Microscope (TEM)

It is much more powerful as compared to the light microscope because it has better magnification and resolution.

- It operates with a beam of **electrons** rather than light.
- Extremely thin slices of the specimen, about 50–90 nm thick, are prepared using an ultramicrotome equipped with a glass knife.
- Electrons pass through an ultra-thin slice of specimen.
- Heavy metal stains like uranyl acetate (for proteins/ nucleic acids) and lead citrate (for lipids/ carbohydrates) are used. These increase electron density *via* positive staining, providing contrast without dissolving in embedding resins.
- Internal details of cells – mitochondria, ribosomes, viruses etc. can be observed.
- Image produced is two – dimensional (2D).
- Resolution can be around 0.1 nm.

9.5.3.2 Scanning Electron Microscope (SEM)

- It operates with a beam of **electrons** rather than light.
- Unlike TEM's ultrathin sections (50-90 nm) cut by glass knives, SEM uses diamond knives for thicker sections or whole mounts.
- Heavy metal coatings provide conductivity for electrons.
- Electrons are reflected from the specimen.
- Electrons scan the surface of the specimen.
- Gives 3D-like images of surfaces – pollen grains, insect legs, microchips.
- Resolution can be around 1 – 20 nm.



Figure 9.6: A. Transmission Electron Microscope B. Scanning Electron Microscope

(Source: Wikimedia commons)

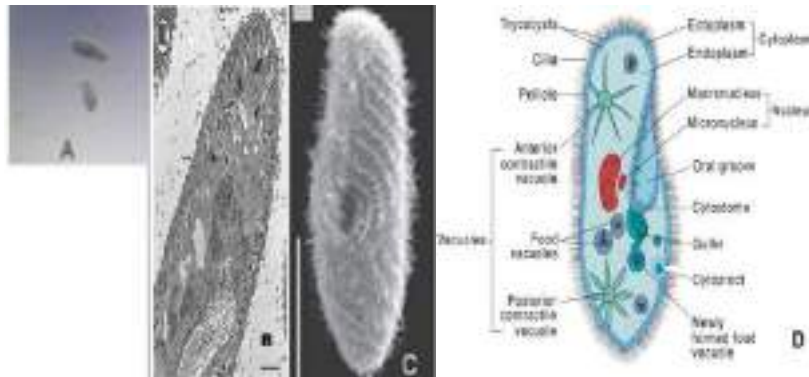

Figure 9.7: *Paramecium* as observed under - A. Light Microscope (Wikimedia commons); B. Transmission electron microscope (Source: Research Gate); C. Scanning electron microscope (Source: Research Gate) and D. Diagrammatic representation.

9.5.3.3 Let us compare Light microscope and Electron microscope (TEM and SEM)

The comparison between these three types of microscopes can be summarised as below:

S. No.	Feature	Light Microscope	Transmission Electron Microscope	Scanning Electron Microscope
1.	Illumination source	Visible light	Electron beam (broad)	Electron beam (focused, scanned)
2.	Types of lenses	Glass (convex, achromatic)	Electromagnetic coils (condenser, objective, projector)	Electromagnetic coils (condenser, scanning, objective)
3.	Thickness of section	Up to several mm - whole mounts; 5 - 10 μ m for tissue sections	Ultra-thin (<100 nm, typically 50-90 nm ultramicrotomy)	Surface only (no sectioning; samples 20 - 30 mm thick, coating 10 -100 nm)
4.	Staining	Basic dyes (e.g., methylene blue, eosin; light-absorbing)	Dense metal compounds, such as uranyl acetate and lead citrate.	Conductive coating (e.g., gold/ palladium; no traditional staining)
5.	Observing living cells	Yes (e.g., pond life, cheek cells)	No (vacuum kills cells)	No (vacuum and the coating kills cells)
6.	Resolution	\sim 0.2 μ m	\sim 0.1 nm or better	\sim 1-10 nm
7.	Magnification	Up to 1,500x	Up to 50 million x	Up to 2 million x
8.	Sample	Minutes	Hours-days	Hours (dehydration,

	preparation time	(simple mounting)	(embedding, ultramicrotomy)	coating)
9.	Cost	Low (~₹10,000-50,000)	Very high (₹50 lakh+)	High (₹20-50 lakh)
10.	Vacuum required	No	Yes	Yes

Think

Why do you think electron microscopes are usually found in big research centres and not in normal school laboratories?

9.6. What is new in Microscopy? What are the limits?

9.6.1 New Developments

With advances in science and technology, digital microscopes are being developed that show a real time image directly on a screen. Thus, live images can be shared with all students at once. In Super-resolution microscopes details smaller than the normal limits of light can be observed. Explore these latest inventions through books, trusted websites, science magazines, and virtual lab simulations, and find out what new things could we discover by using an even better microscope! Your curiosity today may help design the microscopes of tomorrow.

9.6.2 Limitations

- With a light microscope, structures smaller than about 0.2 μm cannot be resolved due to the diffraction limit of light.
- Electron microscopes are costly, need vacuum and very careful sample preparation; most samples have to be processed with chemicals and metal stains.

9.7. Where do we use Microscopes?

You might be surprised how often microscopes quietly support our lives.

- **Hospitals and Pathology laboratories:** Diagnosing diseases by checking blood, sputum, tissue biopsies (e.g., malaria parasites in blood).
- **Science laboratories:** Studying stomata, plant and animal tissues, plant diseases etc.
- **Industry:** Checking quality of metals, plastics, electronic chips using light and electron microscopes.
- **Police and forensics:** Examining fibres, hair, glass fragments, blood stains from crime scenes.
- **Environment:** Checking water samples for algae, protozoa and pollution indicators.

Snapshots

- Microscope (*micro* – small; + *skopion* - "means of viewing") is a special instrument required to observe tiny living organisms or their parts which cannot be seen through naked eyes.
- Different microscopes have varied magnification powers and resolution ranges; the size of the specimen and purpose of observation determines which microscope can be used to view the specimen effectively.
- Magnification is the factor by which a microscope enlarges a specimen's image relative to its actual size (e.g., 400 X).
- Resolution is the smallest distance between two very close points in a specimen to clearly distinguish them as separate and not merged into a single image. It is often expressed as a unit of length e.g. 0.2 μm for light microscopes.
- Light (Optical) microscopes rely on visible light and glass lenses to enlarge and view specimens.
- Light microscopes function by using refraction—the bending of light as it moves between different media due to changes in speed—along with reflection to direct and focus light rays.
- They can be broadly grouped according to the number of lenses used: simple microscopes have a single lens, while compound microscopes contain two or more lenses.
- Fluorescence microscopy uses high-intensity light to excite specialized dyes in a specimen, causing specific cellular structures to glow brilliantly against a dark background like stars in the night sky.
- Phase-contrast microscopy is a premier technique for observing living cells in their native state because it enhances contrast without requiring chemical stains that would compromise cell viability.
- For light microscopy, we can prepare temporary or permanent mount depending upon the short term or long-term storage requirement.
- Electron microscopes use electron beams (shorter wavelength ~ 0.005 nm vs. light 550 nm) accelerated in vacuum, focused by magnetic lenses.
- Electron microscopes are classified as transmission (TEM) or scanning (SEM) based on how the electron beam interacts with the specimen—either passing through it or being reflected from its surface.
- TEM shows internal details of cells in 2D – mitochondria, ribosomes, viruses etc while SEM gives 3D-like images of surfaces.
- In addition to the study of cell and its organelles, microscopes are used for diagnosing diseases, for assessing the quality of metals, plastics, electronic chips, analysis of water samples and in forensics etc.

Check Your Understanding

1. A microscope has a 10X eyepiece and a 40X objective.
 - a) What is its total magnification?
 - b) At this setting, the field of view is 0.4 mm. If 4 cells fit across, estimate the size of one cell.
2.
 - a) You want to watch live protozoa moving in pond water. Which microscope (light, phase-contrast, TEM, SEM) is best and why?
 - b) Neha wants to study the 3D surface of a pollen grain. Which microscope should she choose and why?
3. Riya sees a sharp onion cell image at 100X, but when she switches to 400X, the image is big but very blurred. Name the concept causing this problem. Explain the reason.
4. Draw a ray diagram of a compound microscope.
5. Design a simple poster "How to take care of a microscope?" with three do's and three don'ts.
6. At 40X total magnification, the field diameter is 4 mm. Predict the field diameter at 400X magnification (assume it is inversely proportional to magnification).
7. A student accidentally traps many air bubbles while placing the cover slip. How will this affect observation? Suggest two ways to avoid bubbles next time.
8. Compare TEM and SEM in terms of:
 - Type of image.
 - Best use (internal vs surface).
9. Plan a brief investigation using a school light microscope to compare the purity of three water samples (tap water, RO-purified water, and pond water). Outline the main steps and predict your expected observations.
10. Can we rely on electron microscopes for studying living cells? Explain the reason.
11. List two ways how microscopes are used in hospitals and one way they are used in industries that manufacture mobile phones.
12. Imagine you are Robert Hooke. Write a 5–6 lines diary entry about what you felt when you first saw "little boxes" (cells) in cork.
13. Ananya says, "If we add more and more lenses, we can see anything, even atoms, with a school microscope." Use the idea of resolution to correct this statement.

14. Nishant wants to observe the effect of concentrated salt solution on cells of *Rhoeo* leaf and also wants to keep slides for future reference. Answer the following:
- Which type of mount should be used for this purpose? Give reason.
 - Will the same slide be suitable for long-term storage? Elucidate the reason.
15. Why is it important to fix and dehydrate cheek cells before mounting in Canada Balsam for school laboratory storage? Predict the consequences if a student inadvertently skipped the fixation and dehydration steps before mounting the specimen in Canada Balsam.

References:

- Cell and Molecular Biology: P.K. Gupta
- Laboratory Manual of Cell Biology: Rina Majumdar and Rama Sisodia
- Microbiology – An introduction: Gerrard J. Tortora, Berdell R. Funke and Christine L. Case
- <https://ucmp.berkeley.edu/history/hooke.html#:~:text=Hooke%20had%20discovered%20plant%20cells,the%20cells%20of%20a%20monastery.>
- <https://www.microscope.com/education-center/microscopes-101/compound-microscope-parts>
- <https://pmc.ncbi.nlm.nih.gov/articles/PMC6111892/>
- <https://www.fizzicseducation.com.au/articles/digital-microscopy-teaching-students-biology-their-way/>
- <https://www.microscope.com/education-center/articles/history-of-microscopes>
- [https://bio.libretexts.org/Bookshelves/Microbiology/Microbiology_\(Boundless\)/03:_Microscopy/3.01:_Looking_at_Microbes/3.1D:_Magnification_and_Resolution](https://bio.libretexts.org/Bookshelves/Microbiology/Microbiology_(Boundless)/03:_Microscopy/3.01:_Looking_at_Microbes/3.1D:_Magnification_and_Resolution)
- <https://www.jeolusa.com/RESOURCES/Electron-Optics/Documents-Downloads/sample-preparation-techniques-conductive-coatings1>
- <https://www.leica-microsystems.com/science-lab/life-science/brief-introduction-to-coating-technology-for-electron-microscopy/>
- <https://www.ntnu.edu/documents/139994/141053151/TEM+sample+preparation.pdf/eb6c557f-8243-4923-9135-cc8f8fa5c37f>
- https://www.researchgate.net/figure/TFP-treatment-followed-by-Ca-2-ionophore-A23187-TFP-exposure-was-carried-out-at-the_fig5_16791858
- https://www.researchgate.net/figure/Scanning-electron-micrographs-of-normal-a-and-deciliated-b-paramecia-Note-that-the_fig5_15839897

Engineering Life: Miracles in Biotechnology

10.1 Introduction to Biotechnology

For centuries, humans have relied on living organisms and their properties to improve the quality of life. Whether it is using bacteria to turn milk into curd, using yeast to make the bread we eat, or making the homemade probiotic drink, kanji. By influencing and modifying living organisms through innovation, humans have become engineers of life.



Figure 10.1: Miracles with Biotechnology

Biotechnology refers to the judicious use of living organisms, such as microbes, or their cellular components, to produce substances beneficial to humans. In the modern era, biotechnology has evolved from simple kitchen chemistry to sophisticated genetic engineering.

Human beings have been using biotechnology for a long time. Selective breeding and using the fermentation process for the production of cheese, beer and wine have been practiced since centuries. Today, microbes are not only used to make traditional fermented foods but are also widely exploited in industrial biotechnology for the production of valuable substances such as antibiotics, enzymes, improving the nutritional quality of food items, biofuels and the production of eco – friendly products.

As early as 1973, scientists observed that the genes from microbes can be taken out from one organism and can be inserted in different organism to get a desired altered gene. This branch of biotechnology is called **genetic modification/ genetic engineering/ recombinant DNA (rDNA) technology**, wherein the gene is modified to enhance the production of enzymes, antibiotics, vitamins, hormones (such as insulin), and other industrially significant substances. Thus, Biotechnology has led to advancements in many fields such as medicine, agriculture, animal science and environmental science.

Some common areas where Biotechnology has led to advancements are:

Category	Areas covered
Blue Biotechnology	Application of biotechnology for marine and freshwater organisms, which are used for increasing the seafood supply, regulation of water – borne diseases and developing new drugs.
Green Biotechnology	Improvement in the nutritional quality, quantity and production of eco – friendly products. Development of transgenic plants for better productivity and disease resistance.
Red Biotechnology	Medical Biotechnology, which is applied to manufacture pharmaceutical products such as insulin, enzymes, antibiotics, and vaccines

(Source: Biotechnology: textbook for class XI, NCERT Publication)

Activity 10.1: Observe Fermentation at Home

Aim: To understand microbial action in food.

Materials Required: Warm milk, a spoon of curd, one bowl

Procedure:

1. Pour warm milk into a bowl.
2. Add a spoonful of curd into it.
3. Leave it overnight in a warm place.

Observation: Milk turns into curd.

Conclusion: Microorganisms present in curd convert milk into curd.

Discuss with your parents. In what times or situations does curd take a long time to form? What conditions support the curdling of milk?

Quick Check

1. What is biotechnology?
2. Give two examples from your daily life demonstrating the use of biotechnology.
3. Why are microorganisms important in biotechnology?



Figure 10.2: Biotechnology: Traditional vs Modern

10.2 Traditional vs Modern Biotechnology

Traditional biotechnology includes simple processes used since ancient times.

Example- Making wine, baking bread, brewing beverages. These methods rely on natural microbial activity.

Modern biotechnology uses scientific knowledge and technology to modify organisms. The process of transfer of genes from one organism to another involves a set of molecular techniques that allow scientists to deliberately modify the genetic material of an organism. Herein, specific genes can be “cut” from one organism and “inserted/ pasted” into another.

Examples: Production of insulin using bacteria, disease-resistant crops

Let us research

Activity 10.2: Traditional Biotechnology around you

- **Part A: Research on Fermented Foods:** Make a list of fermented foods used in your home or community. Identify the microorganism that may be responsible for it?
- **Part B: Preparing Probiotic Kanji**

Prepare **kanji**, a traditional fermented drink using **carrot and beetroot**.

- Place chopped carrot and beetroot pieces in a clean glass jar. Add water, salt, and a little mustard powder.
- Keep the jar in sunlight for **2–3 days**, stirring once daily.
- Observe the changes in **aroma, colour, and formation of bubbles**, which indicate microbial activity during fermentation.

Observation: Record your observations and results in the following table.

Day	Changes in Color	Changes in aroma	Presence of Bubbles/Froth	Possible Microbial Activity
Day 1				
Day 2				
Day 3				
Day 4				
Day 5				
Day 6				
Day 7				

Conclusion:

Quick Check

Traditional Biotechnology	Modern Biotechnology
Uses natural microbial processes	Uses _____ techniques
Used since _____ times	Developed in _____ times
Example: Making curd and bread	Example: Production of _____ using bacteria
Has limited control over _____	Provides greater control over _____
Does not involve gene transfer	Involves _____ modification

10.3 Microbes as Tools in Biotechnology

Microorganisms such as bacteria, yeast and fungi are widely used in biotechnology. Why is the reason for this?

- Microbes are easy to grow. Bacteria can double their population in 20 minutes.
- They need basic nutrients (sugar, nitrogen) for their growth.
- They do not need much space, as millions of bacteria can be grown in a small space.
- Their DNA can easily be manipulated.
- Their DNA is self-replicating.

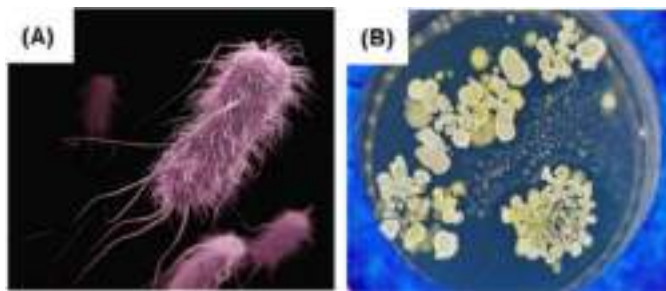

Figure 10.3: (A) Bacteria (B) Fungus

Let us observe

Activity 10.3: Fermentation at home

Mix 2 teaspoons of sugar in a bowl of warm water and add 1 teaspoon of dry yeast.

Cover it and wait for 15 minutes.

Observation: You will observe frothing and a pungent odour emerging.

Discussion: The froth is CO₂, and the smell is due to ethanol.

The yeast is "working" by breaking down sugar.

10.4 Applications of Biotechnology in Daily Life

A casual survey of everyday products reveals that biotechnology plays a key role in many of them. These innovations span diverse fields, transforming how we produce food, medicine, and more.

The following are the key areas involving the use of biotechnology.

1. Crop production and agriculture
2. Medicine and Health Care
3. Food processing
4. Bio-Enzymes: Revolutionizing Household Cleaning
5. Environmental protection

10.4.1 Crop production and agriculture

Genetic engineering of crop plants has enhanced traits like stress tolerance, insect resistance, viral resistance, productivity and nutritional value.

A gene is a segment of DNA that codes for specific proteins. Biotechnology now enables us to manipulate genes of interest to create recombinant DNA, producing genetically modified plants resistant to insect pests—like Bt cotton and Bt corn. Let's explore these examples further.

10.4.1.1 Pest-resistant crops

Bt toxin, a protein from the soil bacterium *Bacillus thuringiensis*, exhibits insecticidal properties. It targets larvae of moths, butterflies, and cotton bollworms but remains harmless to humans. The gene encoding this toxin is transferred to cotton, corn, potato, and tomato plants, creating transgenic varieties. These plants express the Bt toxin, which functions as a natural insecticide, protecting them from insect pests.



Figure 7: Genetically modified plant
e.g.: Bt cotton

These plants are engineered to be "self-protecting" against pests.

- **Source:** A soil bacterium called *Bacillus thuringiensis* (Bt) naturally produces a protein that is toxic for certain insects (like bollworms).
- **Process:** The "toxin gene" from this bacterium is identified, isolated and inserted into the DNA of cotton or corn plants.
- **Result:** The plant starts producing this protein in its leaves and stems. When a pest feeds on the plant, the toxin enters its gut and kills it. This reduces the need for harmful chemical pesticides.

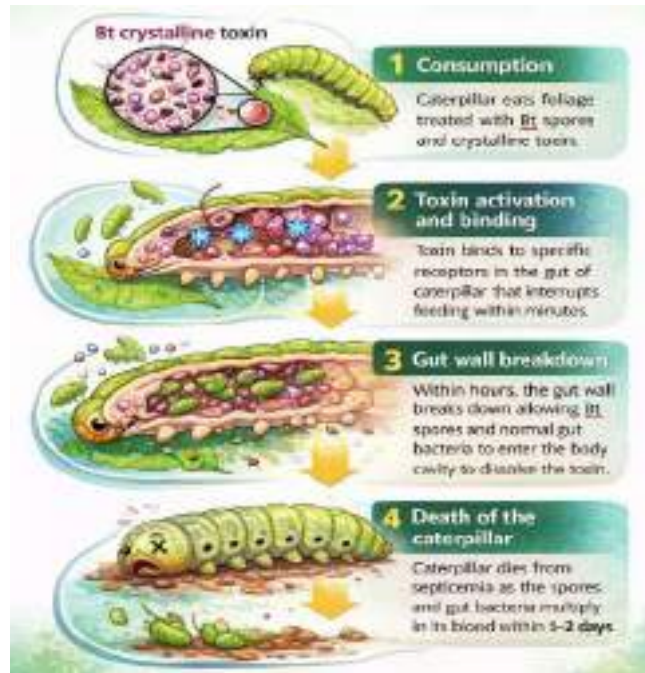

Figure 8: Action of *kurstaki* (Bt) on Caterpillars

10.4.1.2 Improving nutritional quality

Biotechnology has improved the nutritional content of key food crops. A prominent example is Golden Rice, genetically modified to produce high levels of beta-carotene, a precursor to vitamin A.

Golden Rice

- This bio-fortified crop helps fight malnutrition, especially Vitamin A Deficiency (VAD), which causes blindness in millions of children.
- **Problem:** Normal rice is a great source of energy but lacks Vitamin A.
- **Process:** Scientists inserted genes from maize (corn) and a soil bacterium into the rice plant. These genes allow the rice to produce beta-carotene, a precursor to Vitamin A.
- **Result:** The rice grains turn a golden-yellow colour because they are packed with beta-carotene, which our bodies convert into Vitamin A. It acts as a "medicinal food" for people in regions where rice is the main diet.



Figure 9: (A) Normal Rice and (B) Golden Rice

10.4.2 Medicine and Health Care

Making human insulin using bacteria is a brilliant piece of engineering. Instead of relying on animals, scientists "instruct" bacteria how to synthesize human insulin by giving them the right genetic instructions.

Steps:

DNA Isolation

Scientists have identified the specific human gene that contains the gene for making insulin. They use special biological "scissors" called **restriction enzymes** to cut this gene out of human DNA. This leaves "sticky ends" on the gene so it can attach to something else later.

Preparing the Plasmid

Bacteria have small, circular loops of DNA called **plasmids (extracellular DNA)**. Scientists take a plasmid and cut it open using the *same* restriction enzymes used for the human gene. This ensures the plasmid has matching "sticky ends" that fit the human insulin gene perfectly.

Combining the DNA (Ligation)

The human insulin gene is mixed with the cut bacterial plasmid. An enzyme called **DNA ligase** acts like biological glue, joining the two pieces together. This creates a **recombinant plasmid**— a modified DNA that now contains the human instructions for making insulin.

Creating the "Medicine Factory" (Transformation)

This recombinant plasmid is inserted back into a bacterium (usually *E. coli*). The bacterium is now "transformed" and ready to follow its new instructions.

Mass Production and Extraction

The engineered bacteria are placed into a large tank called a **fermenter**. As the bacteria replicate (multiply), they all carry the human insulin gene and begin to "express" it, meaning they start releasing human insulin protein in the culture medium.

Finally, the insulin is collected and purified to be safely used for diabetic patients.

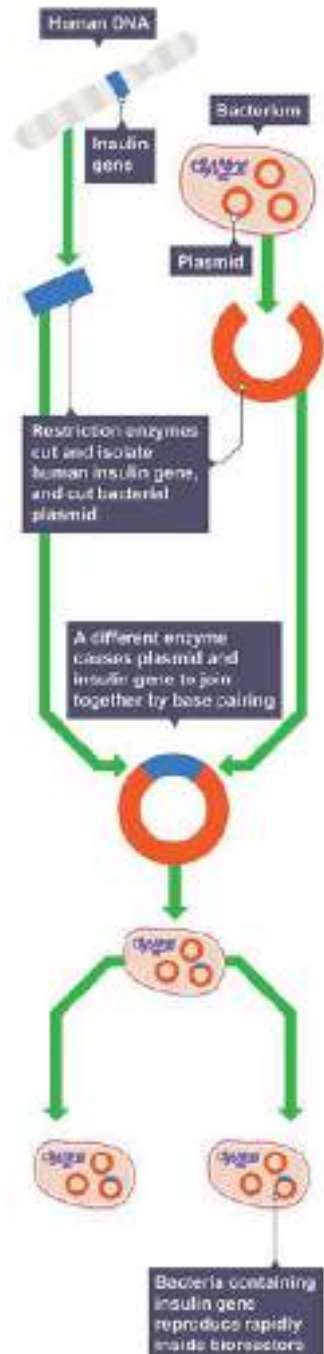

10.4.3 Food processing

Biotechnology plays a key role in the large-scale production of fermented foods like yoghurt, cheese, probiotics, buttermilk, idli, dosa, and dhokla. These products gain improved taste, enhanced nutrition like probiotics for gut health, added vitamins, and longer shelf life (via controlled microbial action). Microorganisms like *Lactobacillus* and yeasts are carefully selected, fermented under optimized conditions, and preserved to produce these foods safely and on a large scale.

10.4.4 Bio-Enzymes: Revolutionizing Household Cleaning

Biotechnology enhances household products through bio-enzymes, natural proteins derived from microbes like bacteria and fungi. These enzymes, such as proteases, amylases, and lipases, power everyday cleaners like laundry detergents, dishwashing liquids, and stain removers by breaking down tough dirt, grease, fats, and proteins at low temperatures—saving energy and reducing harsh chemical use. For instance, in washing powders, bio-enzymes target food stains or grass marks effectively, while in drain openers, they dissolve organic clogs safely without damaging pipes. This makes cleaning eco-friendly, skin-safe, and highly efficient for routine chores.

10.4.5 Environmental protection

Biotechnology contributes to environmental protection through targeted applications like bioremediation and biofuels.

Bioremediation

Microbes, engineered bacteria, or fungi break down pollutants such as oil spills, heavy metals, and pesticides in soil and water. This natural process restores ecosystems without harsh chemicals—for example, *Pseudomonas* bacteria degrade hydrocarbons from industrial waste.

Biofuels

Microbial fermentation converts biomass into renewable fuels like ethanol, biodiesel, or biogas. These alternatives reduce fossil fuel use and greenhouse gas emissions—algae systems even capture CO₂ while growing, aiding cleaner energy and waste management.

10.5. Bioreactors: Powering Large-Scale Biotechnology Applications

Biotechnology's diverse applications—from medicine and agriculture to food production—rely on scalable tools like fermenters (bioreactors) for industrial efficiency.

Fermenters (Bioreactors)

Fermenters are large vessels (up to 100,000 liters) made up of glass or steel that are used to grow microorganisms so as to produce a desired product. Example- A small culture of bacteria or yeast (**inoculum**) is added to fermenters containing nutrient medium to get useful products on a large scale.



Figure 4: Fermenters in Laboratory and Industry

Fermenters must be **sterilized** before use so as to avoid the **contamination** of the rich nutrient culture.

10.5.1 Parts of fermenter-

- **Stirrer (Impeller)**- helps in agitation, i.e., mixes broth so that every cell gets the nutrients and oxygen.
- **Sparger**- Helps in aeration into the tank for the microbes to facilitate aerobic respiration.
- **Cooling Jacket**- Acts as a temperature control when microbes produce heat as they grow. The "cooling jacket" filled with cold water surrounds the tank to prevent the microbes from "cooking" themselves.
- **pH sensors**- Sensors monitor the change in pH. If the broth becomes too acidic, the system automatically adds a "base" to neutralize it.

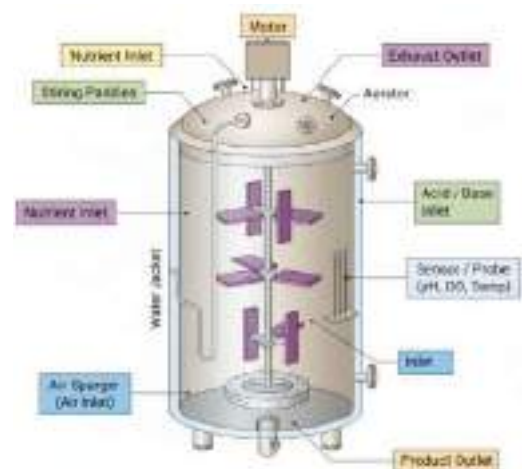

Figure 5: Parts of a fermenter

10.5.2 Fermentation Process

Preparation of Culture Medium



Sterilization of Medium and Equipment



Preparation of Pure Microbial Culture (Inoculum)



Growth of Microorganisms in a Fermenter (Under Controlled Conditions)



Extraction and Purification of Product



Treatment and Disposal of Waste Materials

Quick Check

1. Why is temperature control important in fermenters?
2. What happens if contamination occurs?
3. Explain sterilization and its importance in microbial growth.

10.5.3 Growth of Microorganisms in a Fermenter

Microbial growth does not occur at a constant rate. When nutrients are supplied in a fermenter, microbes pass through different phases of growth, which together form a growth curve.

The following are the phases of growth-

Lag Phase: The new inoculum is added to the nutrients in the fermenter, and the microbes adapt to the new environment. This phase is also called the **acclimatization phase**.

Log Phase: During this phase, microbial cells divide at their optimal rate, resulting in rapid population growth and maximum product formation. This phase is known as the **exponential phase**.

Stationary Phase: This phase is also known as the Survival Phase, wherein nutrients in the fermenters start depleting, and metabolic waste starts building up. Although new cells are being produced, an equal number of cells are dying.

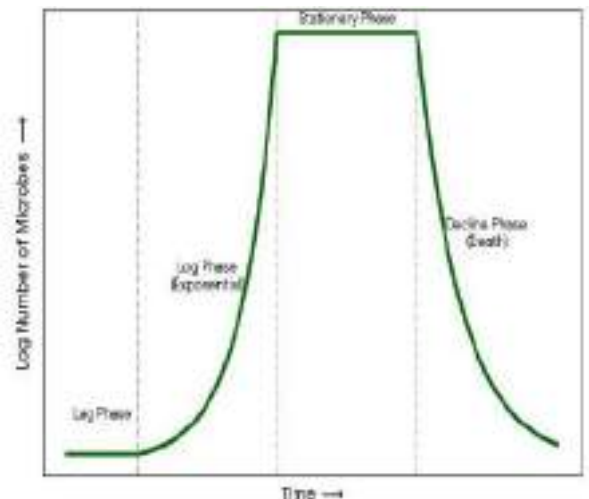

Figure 6: Microbial growth curve

Decline (Death) Phase or The End phase: The toxic waste levels become too high in the fermenter, and the population crashes.

To avoid the Decline (Death) Phase in a fermenter, engineers use a Continuous Culture system. Instead of a closed "batch," the environment is actively managed by:

- **Nutrient Replenishment:** Fresh nutrient medium is added continuously to ensure the microbes never run out of "fuel" for growth.
- **Waste Removal:** An equal volume of "spent" broth (containing toxic metabolic waste) is removed simultaneously. This prevents the buildup of toxins that would otherwise harm the population.
- **Steady State:** Nutrient replenishment and waste removal keep the microbes locked in the Log Phase, where they are most productive.
- **Automatic Buffering:** Sensors detect changes in pH and temperature. If acidic waste builds up, a base is automatically added to maintain a stable, life-supporting environment.

Let us explore like a scientist

Activity 5.4: Growth Simulation

The following table shows hypothetical data representing the growth of microorganisms in a fermenter.

Time (hours)	Number of Microorganisms
0	10
2	12
4	25
6	60
8	120
10	125
12	123
14	90

1. Using the above data, plot a graph using time (hours) on the X-axis and number of microorganisms on the Y-axis.
2. Identify and label the following growth phases on the graph:
 - Lag phase
 - Log phase
 - Stationary phase
 - Death phase

3. During which time period do microorganisms grow most rapidly?
4. Suggest one reason why the population decreases after a certain time.

10.6 Ethical Issues in Biotechnology

10.6.1 Safety: The risk of "Super-bugs" and ecological imbalance

When we try to engineer a microbe to kill a pest or to modify or extract proteins, we are actually introducing a new variable in the ecosystem. This may lead to unintended consequences and require biosafety measures.

Example-

- **Gene Flow:** Modifying genes could mix into the wild through cross-pollination in plants and lead to a risk that will be difficult to control. For example, a "weed-killer resistant" gene from a crop could transfer to a wild weed, creating a "super-weed" that no one can kill.
- **Targeting the Wrong Organisms:** A toxin meant to kill one specific pest might accidentally harm beneficial insects, like bees or butterflies, disrupting the entire food chain and food web.
- **Evolutionary Pressure:** Just as bacteria become resistant to antibiotics, pests can become resistant to the toxins in GM crops (like Bt Cotton), leading to the rise of "super-bugs" that are harder to control than ever before.

10.6.2 Equity: The Global "Biotech Divide"

Science is expensive. Because of the high cost of research and development, biotechnology is often regulated by a few powerful corporations and wealthy nations.

- **Patent Control:** Companies often "own" the seeds or the processes they create through patents. This can prevent poor farmers in developing countries from saving seeds for the next year, forcing them to buy new, expensive seeds every season.
- **Biopiracy:** This happens when researchers do unethical or unlawful appropriation or commercial exploitation of biological materials (such as medicinal plant extracts) that are native to a particular country or territory without providing fair financial compensation to the people or government of that country or territory.
- **Health Access:** Benefits of biotechnology may not reach the middle-income people, as the process and products developed are expensive and may only reach up to the top 1% of the global population, widening the gap between the rich and the poor.

Think and Discuss

There are four important ethical principles that help evaluate the impact of biotechnology on society. These principles act as guidelines to understand the benefits, risks and fairness related to emerging biotechnologies.

The figure shows different modern biotechnologies placed under four ethical principles:

- Beneficence (Doing Good)
- Non-maleficence (Do Not Harm)
- Autonomy (Freedom of Choice)
- Justice and Fairness

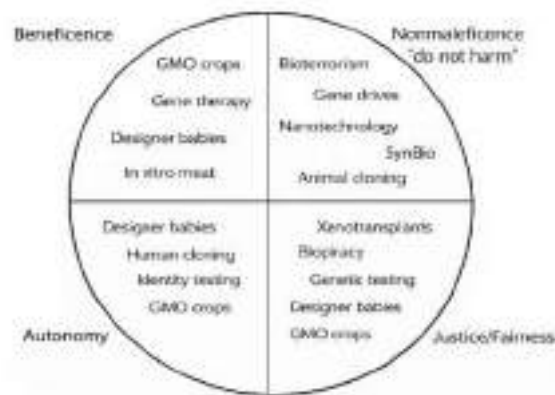

Each emerging biotechnology has been grouped under the principle where ethical concerns may arise. (*SynBio refers to Synthetic Biology.*)

Check Your Understanding

1. Define biotechnology. Explain how microorganisms act as "life's engineers" giving two examples.
2. Differentiate between traditional biotechnology and modern biotechnology using suitable examples.
3. Why are fermenters used instead of open containers for industrial production of useful substances? Give any two reasons.
4. Explain the importance of maintaining sterility inside a fermenter. What problems may arise if sterility is not maintained?
5. Study the diagram of a fermenter in the chapter and answer the questions.
 - A. Identify any two parts responsible for maintaining microbial growth.
 - B. What is the function of the stirrer in a fermenter?
 - C. Why is oxygen supply important in some fermenters?
6. The following data shows the number of microorganisms growing in a fermenter.

Time (hours)	Number of Microorganisms
0	20
2	30
4	70
6	140
8	145
10	140
12	90

Answer the following:

- a) During which time period does rapid microbial growth occur?
 - b) Identify the stationary phase from the data.
 - c) Suggest one reason why the microbial population decreases after a certain time.
7. Microbes are used in food production, medicine and environmental protection. Analyse how biotechnology helps improve human life using any three examples.
 8. A scientist wants to produce insulin using bacteria. Explain how modern biotechnology makes this possible. Why has traditional biotechnology not achieved this?
 9. Biotechnology has helped increase food production, but some people have ethical concerns regarding GM crops. Evaluate both advantages and concerns.
 10. Design a simple biotechnology product that can help solve an environmental problem in your community. Describe:
 - The microorganism or enzyme you would use
 - The problem it solves
 - How it benefits society
 11. Which of the following is an example of traditional biotechnology?
 - a) Production of insulin using bacteria
 - b) Preparation of curd from milk
 - c) Development of disease-resistant crops
 - d) Gene transfer between organisms
 12. Which microorganism is commonly used in bread making?
 - a) Bacteria
 - b) Virus
 - c) Yeast
 - d) Algae

13. Which of the following conditions is necessary for proper functioning of a fermenter?
- a) Contamination
 - b) Controlled temperature
 - c) Open environment
 - d) Absence of nutrients
14. Genetic engineering mainly involves:
- a) Mixing different foods
 - b) Transfer of genes between organisms
 - c) Increasing natural microbial growth
 - d) Removing microorganisms from food
15. During which phase do microorganisms show maximum growth?
- a) Lag phase
 - b) Log phase
 - c) Stationary phase
 - d) Death phase

Assertion (A): Sterility must be maintained inside a fermenter.

Reason (R): Contamination by unwanted microorganisms can reduce product quality.

- a) Both A and R are true and R is the correct explanation of A.
- b) Both A and R are true but R is not the correct explanation of A.
- c) A is true but R is false.
- d) A is false but R is true.

Assertion (A): Modern biotechnology allows production of insulin using bacteria

Reason (R): Modern biotechnology involves genetic modification techniques.

- a) Both A and R are true and R is the correct explanation of A.
- b) Both A and R are true but R is not the correct explanation of A.
- c) A is true but R is false.
- d) A is false but R is true.

References:

1. <https://www.britannica.com/technology/biotechnology>
2. https://www.researchgate.net/figure/There-are-four-ethical-principles-that-may-be-used-as-guidelines-to-assess-the-ethical_fig3_316067580
3. https://agritech.tnau.ac.in/bio-tech/biotech_bt cotton_env.html
4. <https://www.sciencedirect.com/topics/engineering/fermenter>
5. <https://www.sciencedirect.com/topics/engineering/production-fermenter>
6. <https://ncert.nic.in/textbook.php?lebt1=2-13>
7. <https://www.cambridgeinternational.org/programmes-and-qualifications/cambridge-igcse-biology-0610/>
8. [https://bio.libretexts.org/Bookshelves/Human_Biology/Human_Biology_\(Wa_kim_and_Grewal\)/06%3A_DNA_and_Protein_Synthesis/6.08%3A_Biotechnology](https://bio.libretexts.org/Bookshelves/Human_Biology/Human_Biology_(Wa_kim_and_Grewal)/06%3A_DNA_and_Protein_Synthesis/6.08%3A_Biotechnology)
9. <https://pmc.ncbi.nlm.nih.gov/articles/PMC1868753/>
10. <https://www.cdc.gov/ecoli/about/index.html>
11. <https://media.sciencephoto.com/f0/30/28/70/f0302870-800px-wm.jpg>
12. <https://www.bbc.co.uk/bitesize/guides/zr3f7nb/revision/2>
13. <https://www.merriam-webster.com/dictionary/biopiracy>
14. Biotechnology – Textbook for class XI (NCERT Publication)

SCIENCE

Subject Code – 086

Classes IX (2026-27)

Introduction

Science is the study of the natural and physical world around us through a systematic process of observing, questioning, forming hypotheses, testing hypotheses through experiment, analysing evidence, and continuously revising our knowledge. It develops essential skills like curiosity, creativity, evidence-based thinking, and sound decision-making that help us lead rational and fulfilling lives. Learning Science provides valid knowledge about the world, and builds scientific values and capacities. It draws knowledge from Biology, Chemistry, Physics, Earth Science, Mathematics, Computational Sciences, and sometimes Social Science and Vocational Education to offer an interdisciplinary understanding of the role of science.

Science Education helps students to develop an understanding of the natural and physical world through systematic inquiry. Learning Science also develops important capacities, such as observation, questioning, analysis, inference, etc. This helps individuals to meaningfully participate in society and the world of work with a scientific temper, critical and evidence-based thinking, asking relevant questions, analysing practices and norms, and acting for necessary change.

Science Education aims to achieve:

- Scientific understanding of the natural and physical world;
- Capacities for scientific inquiry;
- Understanding the evolution of scientific knowledge;
- Interdisciplinary understanding between Science and other curricular areas;
- Understanding of the relationship between Science, Technology, and Society;
- Scientific temper, and
- Creativity.

Together, the NEP 2020 and NCF-SE 2023 envision science classrooms that encourage curiosity, creativity, collaboration and connection with the real world, ultimately nurturing not just future scientists, but responsible, informed and critically thinking citizens.

Learning standards (Curricular Goals and Competencies) describe what students should know, understand, and be able to do in Science. In Grades 9 – 10, Science is taught using an integrated approach that combines Biology, Chemistry, Physics, and Earth Science. This helps students understand the connections between disciplines and relate Science to their observations and experiences. At this stage, scientific inquiry skills are developed alongside conceptual understanding, with content selected both for disciplinary relevance and real-life usefulness. Students must deepen their understanding of the world, explore scientific questions through discussion and experimentation, and communicate their learning in various ways. It is important to note that the Curricular Goals are interdependent and not separate.

Learning standards are organised into four levels: broad curricular aims define the overall objectives for Science Learning by the end of each schooling stage; more specific Curricular Goals guide the design of the science curriculum for each stage and topic; Competencies

represent measurable scientific skills and knowledge-based on these goals, assessed at the end of each stage; and detailed Learning Outcomes (LOs) are granular milestones of learning and usually progress in a sequence leading to the attainment of a competency. These LOs enable teachers to plan their content, pedagogy, and assessments towards achieving specific competencies.

Curricular Goals (CGs) and Competencies (Cs)

CG 1 – Explores the world of matter, its interactions, and properties at the atomic level

C 1.1 – Describes classification of elements in the Periodic Table, and explains how compounds (including carbon compounds) are formed based on the atomic structure (Bohr's model) and properties (valency).

C 1.2 – Investigates the nature and properties of chemical substances (distillation, crystallisation, chromatography, centrifugation, types and properties of mixtures, solutions, colloids, and suspensions)

C 1.3 – Describes and represents chemical interactions and changes using symbols and chemical equations (acid and base, metal and non-metal, reversible and irreversible)

CG 2 – Explores the physical world around them, and understands scientific principles and laws based on observations and analysis

C 2.1 – Applies Newton's laws to explain the effect of forces (change in state of motion — displacement and direction, velocity and acceleration, uniform circular motion, acceleration due to gravity) and analyses graphical and mathematical representations of motion in one dimension

C 2.2 – Explains the relationship between mass and weight using universal law of gravitation, and connect it to the laws of motion

C 2.3 – Manipulates the position of object and properties of lenses (focus, centre of curvature) to observe image characteristics and correspondence with a ray diagram, and extends this understanding to a combination of lenses (telescope, microscope)

C 2.4 – Manipulates and analyses different characteristics of the circuit (current, voltage, resistance) and mathematises their relationship (Ohm's law), and applies it to everyday usage (electricity bill, short circuit, safety measures)

C 2.5 – Defines work in scientific terms, and represents the relationship between potential and kinetic energy (conservation of energy) in mathematical expressions

C 2.6 – Demonstrates the principle of mechanical advantage by constructing simple machines (system of levers and pulleys)

C 2.7 – Describes the origin and properties of sound (wavelength, frequency, amplitude) and differences in what we hear as it propagates through different instruments

C 2.8 – *Explores interconnected systems and phenomena that support and affect life on Earth (hydrosphere, biosphere, atmosphere, geosphere, cryosphere and their interrelationships, earth processes, hazards, etc.)

*Additional Competency for Earth Science

CG 3 – Explores the structure and function of the living world at the cellular level

C 3.1 – Explains the role of cellular components (nucleus, mitochondria, endoplasmic reticulum, vacuoles, chloroplast, cell wall), including the semi-permeability of cell membrane in making cell the structural basis of living organisms and functional basis of life processes

C 3.2 – Analyses similarities and differences in the life processes involved in nutrition (photosynthesis in plants; absorption of nutrients in fungi; digestion in animals), transport (transport of water in plants; circulation in animals), exchange of materials (respiration and excretion), and reproduction

C 3.3 – Describes the mechanisms of heredity (in terms of DNA, genes, chromosomes) and variation (as changes in the sequence of DNA)

CG 4 – Explores interconnectedness between organisms and their environment

C 4.1 – Applies the knowledge of cellular diversity in organisms along with the ecological role organisms play (autotrophic or heterotrophic nutrition) to classify them into five kingdoms

C 4.2 – Illustrates different levels of organisations of living organisms (from molecules to organisms)

C 4.3 – Analyses different levels of biological organisation from organisms to ecosystems and biomes along with interactions that take place at each level

C 4.4 – Analyses patterns of inheritance of traits in terms of Mendel's laws and its consequences at a population level (using models and/or simulations)

C 4.5 – Analyses evidences of biological evolution demonstrating the consequences of the process of natural selection in terms of changes—in allele frequency in population, structure, and function of organisms

CG 5 – Draws linkages between scientific knowledge and knowledge across other curricular areas

C 5.1 – Explores how literature and arts have influenced Science

C 5.2 – Examines a case study related to the use of Science in human life from the perspective of Social Sciences and Ethics (for example, Marie Curie, Jenner, treatment of patients with mental illnesses, the story of the atomic bomb, green revolution and GMOs, conservation of biodiversity)

C 5.3 – Applies scientific principles to explain phenomena in other subjects (sound pitch, octave, and amplitude in music; use of muscles in dance form and sports)

CG 6 – Understands and appreciates the contribution of India through history, and the present time to the overall field of Science, including the disciplines that constitute it

C 6.1 – Knows and explains the significant contributions of India to all matters (concepts, explanations, methods) that are studied within the curriculum in an integrated manner

CG 7 – Develops awareness of the most current discoveries, ideas, and frontiers in all areas of scientific knowledge in order to appreciate that Science is ever evolving, and that there are still many unanswered questions

C 7.1 – States concepts that represent the most current understanding of the matter being studied, ranging from mere familiarity to conceptual understanding of the matter as appropriate to the developmental stage of the students

C 7.2 – States questions related to matters in the curriculum for which current scientific understanding is well-recognised

CG 8 – Explores the nature of Science by doing Science

C 8.1 – Develops accurate and appropriate models (including geometric, mathematical, graphical) to represent real-life events and phenomena using scientific principles, and use these models to manipulate variables and predict results

C 8.2 – Designs and implements a plan for scientific inquiry (formulates hypotheses, makes predictions, identifies variables, accurately uses scientific instruments, represents data— primary and secondary—in multiple modes, draws inferences based on data, and understanding of scientific concepts, theories, laws and principles, and communicates findings using scientific terminology)

COURSE OUTLINE

CLASS IX (2026-27)

Cell

No. of Periods: 12

Key Concepts		Learning Outcomes
<ul style="list-style-type: none"> • Discovery of cell • Plant and animal cells • Prokaryotic and eukaryotic cells • Cell as a structural and functional unit of life; structure and function of key organelles (nucleus, mitochondria, chloroplast, endoplasmic reticulum, vacuoles, plasma membrane, cell wall) • Permeability of cell membranes • Cellular division and cancer • Recent advancement in cell biology 	C-3.1	<ul style="list-style-type: none"> • Differentiate between plant and animal cell, prokaryote and eukaryote • Describe the structural and functional features of cells • Explain the role of cells in the structure and functions of organisms • Explain activities inside the cell and its interactions with the environment • Demonstrate osmosis in cells • Prepare slides to observe cell structure
	C-3.2	<ul style="list-style-type: none"> • Differentiate between diffusion and osmosis
	C-3.3	<ul style="list-style-type: none"> • Explain the role of cell division mitosis and meiosis in creating similarities and variations
	C-4.2	<ul style="list-style-type: none"> • Identify and describe the role of biomolecules in the structure and function of cell
	C-5.2	<ul style="list-style-type: none"> • Cite case study related to the use of science in human life, for example, Leigh Syndrome and mitochondrial dysfunction
	C-5.3	<ul style="list-style-type: none"> • Apply learning of a structure and function of muscles cells or joints in dance form and/or sports
	C-6.1	<ul style="list-style-type: none"> • Discuss significant contributions of India, for example, Professor Arun Kumar Sharma for his work on chromosomes and methods for its studies
	C-7.1	<ul style="list-style-type: none"> • Recognise that the cell is a structural unit of life and functional unit of life processes
	C-7.2	<ul style="list-style-type: none"> • Pose questions, such as — Can we create artificial cell which behaves exactly like a natural living cell?

	C-8.1	<ul style="list-style-type: none"> Exhibit creativity and design models using low cost or no-cost eco-friendly material to study structure and functions of cell and cell organelles
	C-8.2	<ul style="list-style-type: none"> Carry out an experiment to understand the osmosis Analyze result and present finding using scientific terms

Tissues

No. of Periods: 13

Key Concepts		Learning Outcomes
<p>Tissues: Introduction and importance</p> <ul style="list-style-type: none"> Level of organisation in the living organisms Plant and animal tissues Types of plant tissues Meristematic tissues (types and function of each) Permanent tissues (types, structure and function of each) Animal tissues Overview (epithelial, connective, muscular and nervous tissues — types, structure and function of each) Elementary idea of musculoskeletal system Care of musculoskeletal system: injuries, postural care, nutrition and exercise 	C-4.2	<ul style="list-style-type: none"> Differentiate between plant and animal tissues; meristematic and permanent tissues; simple and complex tissues; parenchyma, collenchyma and sclerenchyma; xylem and phloem; striated smooth and cardiac muscles; Different types of joints Relate the structure of the different types of tissues with their functions Explain the role of various types of tissues in plants and animals Describe the level of organisation in a multicellular organism
	C-5.3	<ul style="list-style-type: none"> Establish the correlation between different tissues for fitness, for example, role of muscles, cartilage and bones in facilitating movement
	C-6.1	<ul style="list-style-type: none"> Explain the importance of yoga exercises for physical agility and in maintaining the correct posture
	C-6.1	<ul style="list-style-type: none"> Discuss significant contributions of India, for example, Professor Sipra Guha Mukherjee and Professor S.C. Maheshwari for their significant contribution in the plant cell and tissue culture research in India
	C-7.1	<ul style="list-style-type: none"> Discuss the techniques and medical recommendations in recovery from muscular injuries

	C-8.2	<ul style="list-style-type: none"> • Carry out an experiment to understand the growth in plant due to apical meristem • Represent data in multiple modes, including appropriate figures, tables, graphs, or digital formats, interpret and draw inferences from the data • Analyse results and present findings using scientific terms • Communicate findings and conclusions effectively, such as those from experiments, activities, or projects, both orally and in written form
--	-------	---

Reproduction

No. of Periods: 13

Key Concepts		Learning Outcomes
<ul style="list-style-type: none"> • Introduction to different forms of reproduction — sexual and asexual • Types of asexual reproduction with examples • Sexual reproduction in flowering plants (flower and its parts, pollination, fertilisation, seed dispersal) • Sexual reproduction in humans: male and female reproductive systems (structure and function, formation of gametes, sperm and egg, fertilisation, pregnancy and development of embryo, menstrual cycle) • Reproductive health and hygiene • Introduction to birth control methods and importance 	C-2.8	<ul style="list-style-type: none"> • Analyse the interactions between members of different groups of organisms, such as plants and pollinators
	C-3.2	<ul style="list-style-type: none"> • Compare asexual and sexual reproduction • Describe male and female reproductive organs in plants and animals • Differentiate between ovule and seed; ovary and fruit • Explain pollination and fertilisation
	C-3.3	<ul style="list-style-type: none"> • Explain how variations are introduced by sexual reproduction
	C-4.3	<ul style="list-style-type: none"> • Identify and explain the role of biotic and abiotic agents in seed dispersal and pollination
	C-5.1	<ul style="list-style-type: none"> • Illustrate the structure of male and female reproductive units or systems in plants and animals
	C-5.2	<ul style="list-style-type: none"> • Recognise the significance of contraceptive devices for population control and health including reproductive health
	C-6.1	<ul style="list-style-type: none"> • Describe the contribution of India to the understanding of human anatomy
	C-6.1	<ul style="list-style-type: none"> • Discuss significant contributions of India, for example, Professor Panchanan Maheshwari for

		laying the foundation of plant cell and tissue culture research in India
	C-7.1	<ul style="list-style-type: none"> Recognise the importance of improvements in medical field for assisted reproductive technologies
	C-7.2	<ul style="list-style-type: none"> Pose questions, such as — How do heavy metals harm reproductive organs? Can extreme heat affect fertility?

Diversity

No. of Periods: 12

Key Concepts		Learning Outcomes
<ul style="list-style-type: none"> Importance of classification Five kingdoms and their key features with examples Major division of animals and plants Binomial nomenclature Acellular entities: viruses 	C-4.1	<ul style="list-style-type: none"> Distinguish organisms based on certain characteristics, such as number of cells present, cellular organisation and mode of nutrition Classify various organisms in groups, such as five kingdoms, on the basis of their cellular organisation and ecological role Describe the significance and rules of binomial nomenclature Apply binomial nomenclature on some common organisms in their surroundings
	C-2.8	<ul style="list-style-type: none"> Analyse the interactions between members of different groups of organisms, such as lichens Discuss ecological role of diverse organisms
	C--7.1	<ul style="list-style-type: none"> Recognise three domains of classification of organisms on molecular basis

Exploring Mixtures and their Separation

No. of Periods: 12

Key Concepts		Learning Outcomes
<ul style="list-style-type: none"> Homogeneous and heterogeneous mixtures; Solutions, suspensions, colloids and their properties Various ways to express concentration of solutions (mass by mass percentage of a solution, 	C-1.2	<ul style="list-style-type: none"> Differentiate between homogeneous and heterogeneous mixtures on the basis of their properties Demonstrate separation techniques, such as crystallisation, distillation, paper chromatography, sublimation, centrifugation and coagulation Classify mixtures as solutions, suspensions, or colloids based on their properties Explain the scientific principles behind different

<p>mass by volume percentage of a solution, volume by volume percentage of a solution)</p> <ul style="list-style-type: none"> Separation techniques based on the physical properties of components, including crystallisation, distillation, paper chromatography, sublimation, centrifugation and coagulation 		<p>separation techniques</p> <ul style="list-style-type: none"> Apply the knowledge of homogeneous and heterogeneous mixtures in daily life Define and calculate the concentration of solutions using mass by mass percentage, mass by volume percentage, volume by volume percentage Analyse graphs of solubility and explain how the solubility of substances changes with temperature Use scientific conventions and standard units to express concentrations Handle common laboratory chemicals and apparatus safely Relate separation techniques with practices observed in the local environment
	C-5.1	<ul style="list-style-type: none"> Draw labelled diagrams or flow charts of separation techniques
	C-5.2	<ul style="list-style-type: none"> Display awareness about the societal impact of chemistry in making life healthier, cleaner and sustainable
	C-5.3	<ul style="list-style-type: none"> Correlate the phenomenon used in centrifugation to the spinning dance
	C-6.1	<ul style="list-style-type: none"> Describe the cultural practices, like traditional methods of distillation Display awareness about the contributions of Indian scientists, such as Dilip Mahalanabis
	C-7.1	<ul style="list-style-type: none"> Demonstrate the use of small-scale or micro-scale experiments, such as crystallisation of copper sulfate, as an alternative to traditional methods
	C-7.2	<ul style="list-style-type: none"> Poses question, such as — Can we create artificial blood that works just as real blood for all patients?
	C-8.1	<ul style="list-style-type: none"> Exhibit creativity and work collaboratively in groups to create models of apparatus used for separating mixtures, such as a paperfuge and a distillation unit, using eco-friendly materials
	C-8.2	<ul style="list-style-type: none"> Formulate hypotheses about scientific phenomena based on prior knowledge and understanding of scientific concepts, and predict the results of an experiment or investigation based on their hypotheses

		<ul style="list-style-type: none"> • Accurately use scientific instruments, apparatus and chemicals to collect data • Analyse results and findings using scientific terms • Represent findings in multiple modes, including appropriate figures, tables, graphs, or digital formats, and interpret and draw inferences from the findings • Communicate findings and conclusions effectively, such as those from experiments, activities or projects, both orally and in written form
--	--	--

Structure of an Atom

No. of Periods: 14

Key Concepts		Learning Outcomes
<ul style="list-style-type: none"> • Atoms are the basic units of elements • Atoms consist of subatomic particles • Atomic Models (Thomson's Model, Rutherford's Model, and Bohr's Model) • Distributions of electrons in elements (up to 18 elements) • Symbols • Valency as the combining capacity • Atomic number • Mass number • Isotopes • Isobars 	C-1.1	<ul style="list-style-type: none"> • Differentiate between subatomic particles (electrons, protons, and neutrons) based on their charge, and position in the atom • Illustrate how electrons are distributed in different energy levels, such as K, L, M, N ... or by numbers $n = 1, 2, 3, 4 \dots$ • Explain valence electrons, valency, atomic number, atomic mass, isotopes, and isobars • Calculate the number of electrons, protons, and neutrons of an element using its atomic and mass numbers • Interpret data, such as atomic mass, maximum number of electrons in a shell, and valency to classify elements accurately • Use scientific conventions as per international standards, such as notations for electron, proton, neutron, unified atomic mass unit (u), and distribution of electrons in various shells, such as K, L, M, N ...
	C-1.3	<ul style="list-style-type: none"> • Recognise and accurately apply the chemical symbols for the first eighteen elements according to IUPAC
	C-5.1	<ul style="list-style-type: none"> • Draw labelled diagrams of various atomic models, such as Thomson's model, Rutherford's model and Bohr's model • Create and present a role play, stage play, or story of 'Journey Inside the Atom' to display awareness about the contributions of key scientists in the

		discovery and development of atomic structure
	C-5.2	<ul style="list-style-type: none"> • Display awareness about the role of Indian scientists and their contributions to atomic science for peaceful purposes and explore how their works influenced India's scientific development
	C-5.3	<ul style="list-style-type: none"> • Display awareness about the societal impact of science in making life healthier, like the use of various isotopes in medicines to treat different diseases, and atomic energy in power generation • Design and develop games that utilise atomic number, mass number, and subatomic particle clues to accurately predict and identify elements
	C-6.1	<ul style="list-style-type: none"> • Display awareness about the contributions of the ancient Indian philosopher, Acharya Kanad's idea of indivisible particles (Parmanu)
	C-7.1	<ul style="list-style-type: none"> • Describe the use of the atomic mass unit (u) to measure the mass of atoms as per IUPAC recommendations • Describe scientific discoveries that explain how the structure of the atom has evolved over time through various atomic models proposed by different scientists
	C-7.2	<ul style="list-style-type: none"> • Pose question, such as—is it possible to completely understand everything that happens inside an atom?
	C-8.1	<ul style="list-style-type: none"> • Exhibit creativity and work collaboratively in groups to design different models of atoms
	C-8.2	<ul style="list-style-type: none"> • Formulate hypotheses about scientific phenomena by applying prior knowledge and understanding of scientific concepts, and predict the results of data based on the hypotheses • Analyse results and present findings using scientific terms • Correlate the results and conclusions of different models of atomic structure • Represent data in multiple modes, including appropriate figures, tables, graphs or digital formats, and interpret and draw inferences from the data

		<ul style="list-style-type: none"> Communicate findings and conclusions effectively, such as those from experiments, activities or projects, both orally and in written form
--	--	---

Atoms and Molecules

No. of Periods: 14

Key Concepts		Learning Outcomes
<ul style="list-style-type: none"> Law of conservation of mass Law of constant proportion Dalton's Atomic theory Molecules of elements, Molecules of covalent compounds and their properties Ions, Ionic compounds and their properties Writing chemical formulae Molecular mass Formula unit mass 	C-1.1	<ul style="list-style-type: none"> Differentiate between chemical species based on their properties or characteristics, such as atoms and molecules, elements and compounds, ionic and covalent compounds, cations and anions, formula unit mass and molecular mass Plan and demonstrate activities to observe and verify the law of conservation of mass Explain the Dalton's atomic theory, the law of conservation of mass, the law of constant proportions, and formation of ionic and covalent compounds Calculate the charge on an ion, valency from the atomic number, the molecular and formula unit mass Use scientific conventions, symbols, and valency to write the chemical formulae of simple compounds Display awareness about the scientific discoveries, such as the contributions of Antoine Lavoisier, Joseph Proust, and John Dalton Handle common laboratory chemicals and apparatus safely
	C-5.1	<ul style="list-style-type: none"> Draw diagrams of electron dot structures of atoms and molecules
	C-5.2	<ul style="list-style-type: none"> Describe how atoms and molecules can lead to beneficial applications, such as medicine, energy and peaceful use of atomic science Relate atomic bonding to social bonding
	C-5.3	<ul style="list-style-type: none"> Design educational games to write chemical formulae using symbols
	C-6.1	<ul style="list-style-type: none"> Display awareness about the contributions of Indian scientists in promoting the peaceful use of atomic energy and the traditional use of the red pigment 'cinnabar' obtained from rocks

	C-7.1	<ul style="list-style-type: none"> Describe the basic concepts that matter are made of particles; elements combine in fixed ratios to form compounds; the law of conservation of mass; and different types of bonding (ionic and covalent)
	C-7.2	<ul style="list-style-type: none"> Pose question, such as — Are there any chemical changes that do not obey the law of conservation of mass?
	C-8.1	<ul style="list-style-type: none"> Exhibit creativity and work collaboratively in groups to construct simple models of compounds
	C-8.2	<ul style="list-style-type: none"> Formulate hypotheses about scientific phenomena by applying prior knowledge and understanding of scientific concepts and laws, and predict the results of data based on the hypotheses Accurately use scientific instruments, apparatus and chemicals to collect data Analyse results and findings using scientific terms Represent data in multiple modes, including appropriate figures, tables, graphs or digital formats Communicate findings and conclusions effectively, such as those from experiments, activities or projects, both orally and in written form

Earth as a System: Energy, Matter & Life

No. of Periods: 12

Key Concepts		Learning Outcomes
<ul style="list-style-type: none"> Earth as interconnected system Nature of solar energy: solar radiation, electromagnetic spectrum, and speed of light Solar energy interaction with the Earth's Surface and differential heating of the Earth (the role of the atmosphere and the Earth's surface) Differential warming of the Earth causes winds 	C-2.8	<ul style="list-style-type: none"> Explain the interconnectedness between different spheres of the Earth (biosphere, geosphere, hydrosphere, cryosphere and atmosphere) Explain the nature of solar radiation Explain that solar radiation is an electromagnetic waves having different Frequencies Explain how heat from the Sun warms the Earth's surface differently based on the shape, latitude and tilt of the Earth Explain the interaction of solar radiation with the Earth's surface and relate the differential heating of the Earth's surface with the atmospheric phenomena, such as air movement, evaporation, etc., and describe phenomena like mountain, valley, sea and land breezes

<ul style="list-style-type: none"> • Biogeochemical cycles (water cycle, carbon cycle, nitrogen cycle, oxygen cycle) • Human impact on Earth's system 		<ul style="list-style-type: none"> • Describe how the latitude and tilt of the Earth, and absorption and reflection of solar radiation by different surfaces cause differential heating of the Earth's surface • Identify various components of the Earth that interact with solar energy • Explain the role of the atmosphere in influencing weather and climate on the Earth • Identify the reflectivity of different materials through reliable scientific sources, such as the internet and books • Describe how elements like carbon, nitrogen, oxygen and water are recycled between biotic and abiotic environments • Explain biogeochemical cycles, and the roles of biogeochemical cycles in circulating matter and energy continuously between the non-living environment (abiotic) and living (biotic) organisms, making nutrients available, and maintaining environmental balance
	C-6.1	<ul style="list-style-type: none"> • Reflect the changing nature of Earth's environment through our traditional knowledge
	C-7.2	<ul style="list-style-type: none"> • Pose questions, such as — What will happen if there is no differential heating of the Earth?
	C-8.1	<ul style="list-style-type: none"> • Draw flow charts, concept maps for biogeochemical cycles, differential heating of the Earth's surface and Electromagnetic spectrum
	C-8.2	<ul style="list-style-type: none"> • Formulate hypotheses about scientific phenomena based on prior knowledge and understanding of differential heating of the Earth and biogeochemical cycle • Predict the results of an experiment or investigation based on their hypotheses • Communicate findings and conclusions effectively, such as those from experiments, activities or projects, both orally and in written form

Motion**No. of Periods: 13**

Key Concepts		Learning Outcomes
<ul style="list-style-type: none">• Motion — displacement, velocity, acceleration• Graphical representation of motion for an object moving in a straight line in one direction (with constant velocity, and constant acceleration)• Kinematic equations for motion in a straight line with constant acceleration (by graphical method)• Elementary idea of uniform circular motion	C-2.1	<ul style="list-style-type: none">• Differentiate between distance travelled and displacement, and speed and velocity for objects moving in a straight line• Define displacement, velocity, acceleration, and uniform circular motion• Express displacement, velocity, acceleration in appropriate SI units• Plot and interpret position-time graphs and velocity-time graphs to describe the motion of an object moving in a straight line in one direction (with constant velocity and constant acceleration)• Calculate average velocity from position-time graph, displacement and average acceleration from velocity-time graph• Derive kinematic equations for motion in a straight line with constant acceleration by graphical method• Calculate values of unknown physical quantities from the given physical quantities, using kinematic equations• Derive the expression of speed for uniform circular motion
	C-8.1	<ul style="list-style-type: none">• Analyse real-life events and phenomena, and identify the key factors that influence their Behaviour.
	C-8.2	<ul style="list-style-type: none">• Formulate hypotheses about scientific phenomena based on prior knowledge and understanding of scientific concepts, theories, laws, and principles• Predict about the outcome of an experiment or investigation based on their hypotheses• Identify the variables that are relevant to a scientific investigation and determine how to control or manipulate them• Accurately use scientific instruments and equipment to collect data• Represent data in multiple modes, including tables, graphs and visual representations, and interpret and draw inferences from the data• Communicate their findings using scientific terminology and effectively communicate their conclusions to others

Force and Laws of Motion**No. of Periods: 13**

Key Concepts		Learning Outcomes
<ul style="list-style-type: none">• Force; balanced and unbalanced forces• Force of friction• Newton's first law of motion• Newton's second law of motion• Newton's third law of motion	C-2.1	<ul style="list-style-type: none">• Explain that force has magnitude as well as direction• Identify situations in which balanced and unbalanced forces are acting on an object• Explain the role of friction on the motion of objects• Recognise that for an object moving with constant velocity, the net force is zero, whereas a change in velocity (acceleration) is caused by a force• State and explain Newton's first law of motion• State and explain Newton's second law in terms of mass and acceleration• Calculate force using mathematical expression of Newton's second law of motion• Define SI unit of force• State and explain Newton's third law of motion• Apply Newton's laws of motion to explain everyday life events
	C-8.1	<ul style="list-style-type: none">• Analyse real-life events and phenomena, and identify the key factors that influence their behaviour• Develop a model to represent real-life event• Use models to manipulate variables and predict results
	C-8.2	<ul style="list-style-type: none">• Formulate hypotheses about scientific phenomena based on prior knowledge and understanding of scientific concepts, theories, laws, and principles• Predict about the outcome of an experiment or investigation based on their hypotheses• Identify the variables that are relevant to a scientific investigation and determine how to control or manipulate them• Accurately use scientific instruments and equipment to collect data• Represent data in multiple modes, including tables, graphs and visual representations, and interpret and draw inferences from the data• Communicate their findings using scientific terminology and effectively communicate their conclusions to others

Work, Energy and Simple Machines**No. of Periods: 13**

Key Concepts		Learning Outcomes
<ul style="list-style-type: none">• Concept of work; work done by a constant force• Work-Energy theorem• Mechanical energy, kinetic and potential energy, and conversion between potential energy and kinetic energy• Conservation of energy• Power• Simple machines and their mechanical advantage (pulley, inclined plane, lever)	C-2.5	<ul style="list-style-type: none">• Define work done by a constant force and its SI unit• Calculate work done by a force using mathematical expression• State work-energy theorem• Explain the concept of energy and state its SI unit• Name forms of energy and identify their interconversion in surroundings (elementary idea)• Define kinetic energy of a moving object and derive its mathematical expression• Define potential energy for an object raised to a height and derive its mathematical expression• Calculate kinetic and potential energy using mathematical expressions• Explain conversion between potential energy and kinetic energy (for the case of an object under free fall)• State the law of conservation of energy• Define power and its unit• Calculate power using its mathematical expression
	C-2.6	<ul style="list-style-type: none">• Identify different simple machines (pulley, inclined plane and lever)• Define mechanical advantage and calculate its value for simple machine• Demonstrate and explain mechanical advantage of simple machines their conclusions to others
	C-8.1	<ul style="list-style-type: none">• Analyse real-life events and phenomena, and identify the key factors that influence their behaviour• Develop model to represent real-life event• Use models to manipulate variables and predict results
	C-8.2	<ul style="list-style-type: none">• Formulate hypotheses about scientific phenomena based on prior knowledge and understanding of scientific concepts, theories, laws, and principles• Predict about the outcome of an experiment or investigation based on their hypotheses• Identify the variables that are relevant to a scientific

		<p>investigation and determine how to control or manipulate them</p> <ul style="list-style-type: none"> • Accurately use scientific instruments and equipment to collect data • Represent data in multiple modes, including tables, graphs and visual representations, and interpret and draw inferences from the data • Communicate their findings using scientific terminology and effectively communicate their conclusions to others
--	--	---

Sound

No. of Periods: 11

Key Concepts		Learning Outcomes
<ul style="list-style-type: none"> • Production of sound • Propagation of sound (as a longitudinal wave through a medium) • Graphical representation of sound wave • Characteristics of sound wave (wavelength, frequency, time period, amplitude, intensity, speed) • Human perception of sound (pitch, loudness) • Propagation of sound in different media (solid, liquid) • Reflection of sound (echo, reverberation), echolocation 	C-2.7	<ul style="list-style-type: none"> • Demonstrate the production of sound in multiple ways (through vibration of strings, membranes, air columns) using materials in surroundings • Explain that sound is produced by vibrations • Demonstrate that sound can travel through different mediums (air, solid and liquid) • Describe that sound needs a medium for propagation • Explain that sound travels as a longitudinal wave • Describe the characteristics of sound waves the (wavelength, frequency, time period, amplitude, intensity and speed) • Analyse graphs representing sound • Write relationship between time period and frequency of sound wave • Derive mathematical expression for speed of sound • Calculate speed of sound using its mathematical expression • Explain human perception of sound in terms of audible range, loudness and pitch of sound • Describe reflection of sound, and apply it to echo and reverberations in surroundings • Explain the use of sound waves for echolocation
	C-5.3	<ul style="list-style-type: none"> • Describe music in terms of characteristics of sound waves, such as loudness and pitch
	C-6.1	<ul style="list-style-type: none"> • Name historical buildings designed for echoes, such as whispering gallery of Gol Gumbaz

		<ul style="list-style-type: none"> • Display awareness about Sir C.V. Raman
	C-8.1	<ul style="list-style-type: none"> • Analyse real-life events and phenomena, and identify the key factors that influence their behaviour • Develop model to represent real-life event • Use models to manipulate variables and predict results
	C-8.2	<ul style="list-style-type: none"> • Formulate hypotheses about scientific phenomena based on prior knowledge and understanding of scientific concepts, theories, laws, and principles • Predict about the outcome of an experiment or investigation based on their hypotheses • Identify the variables that are relevant to a scientific investigation and determine how to control or manipulate them • Accurately use scientific instruments and equipment to collect data • Represent data in multiple modes, including tables, graphs and visual representations, and interpret and draw inferences from the data • Communicate their findings using scientific terminology and effectively communicate their conclusions to others

Practical will be announced shortly.

Assessment Structure	Marks
Annual Examination (03 hrs.)	80 Marks
Internal Assessment <ul style="list-style-type: none"> • Periodic Assessment - 05 marks + 05 marks • Subject Enrichment (Practical Work) - 05 marks • Portfolio - 05 marks 	20 Marks
Total	100 Marks

PRESCRIBED BOOKS:

- Science-Textbook for class IX-NCERT Publication
- Assessment of Practical Skills in Science-Class IX - CBSE Publication
- Laboratory Manual-Science-Class IX, NCERT Publication
- Exemplar Problems Class IX – NCERT Publication

Social Science
Subject Code-087
Class - IX (2026-27)

RATIONALE

The purpose of the education system is to develop good human beings capable of rational thought and action, possessing compassion and empathy, courage and resilience, scientific temper and creative imagination, with sound ethical moorings and values. It aims at producing engaged, productive and contributing citizens for building an equitable, inclusive and plural society as envisaged by our Constitution. [NEP 2020, pages 4-5]

Social Science is a compulsory subject at Secondary Stage Phase-I of school education. Social Science can play a unique role within the school curriculum to enable Knowledge, Capacities, and Values and Dispositions that underpin the purpose of education as committed to in NEP 2020.

The teaching and learning of Social Science at the secondary stage is aligned with the transformational vision of the National Curriculum Framework for School Education (NCF-SE) 2023 and the National Education Policy (NEP) 2020. The NCF-SE 2023 emphasises learning, i.e., competency-based, inquiry-oriented, and rooted in Indian Knowledge Systems (IKS) and lived realities. The deliberate reduction of content load with a focus on core concepts rather than memorisation, creates space for discussion, exploration, and deep understanding. The framework's call for interdisciplinarity encourages students to draw meaningful connections across disciplines and relate classroom learning to real-life contexts and experiences.

Furthermore, the NCF-SE 2023 envisions rootedness in India, in which learning is grounded in India's diverse heritage and intellectual traditions, while also being combined with a global outlook. Within this perspective, Social Science education engages students with India's historical experiences, democratic values, and patterns of economic and social development, geographical understanding alongside global processes and contemporary challenges. By integrating the aims of the NEP 2020, Social Science education seeks to transform learning into a process that builds knowledge, capacities, and values essential for personal growth, social harmony and national progress.

Social Science at the secondary stage is an integrated study of human society like its evolution, structures, and dynamics through the disciplines of History, Geography, Political Science, and Economics. It explores how societies function and transform over time through the interplay of historical, geographical, cultural, political, economic, and environmental forces. The subject goes beyond the factual understanding to include inquiry, interpretation, and analysis.

Students learn to source and validate information, interpret data and evidence, and construct logical explanations, thus fostering critical and reflective thinking. It also cultivates empathy, respect for diversity, and a sense of justice and responsibility — values that reflect India's intellectual traditions of reasoning, dialogue, and debate as pathways to truth and understanding.

AIMS & OBJECTIVE

As per NCF- 2023, the aims of teaching Social Science in school education can be summarised as follows:

- a. Develop disciplinary knowledge and understanding of how society functions through an interplay of historical, geographical, social, economic, and political factors.

This can be enabled through:

- i. an understanding of continuity and change in human civilisation, its causation and effect and its impact on modern life.
 - ii. an understanding of the interaction between nature and human beings, the spatial patterns arising out of this interaction and its effect on human life.
 - iii. an awareness and understanding of the diversity of people and their practices in different societies, regions and cultures within societies.
 - iv. an awareness of various social, political and economic institutions, their origin, functioning and transformations over time.
- b. Develop an understanding and appreciation for the methods of enquiry relevant to Social Science and deepen students' skills to engage with the key questions and issues confronting society.

These could be specifically seen as:

- i. Skills in sourcing evidence, interpreting them, checking through multiple sources and evidences and constructing a coherent narrative.
 - ii. Skills in recognizing spatial patterns, map-reading, interpretation and analysis of various interconnected concepts and processes.
 - iii. Skills of creative and analytical thinking to form informed opinions, demonstrate logical decision-making and incline towards a problem- solving attitude.
 - iv. Skills to collect, organize, analyse, represent, and present data and information on various historical, geographical, and socio-political issues.
 - v. Skills to question unsubstantiated ideas, biases, stereotypes, and assumptions to foster scientific temper and propose meaningful responses to contemporary concerns of society.
- c. Foster ethical, human, and Constitutional values:

As the NEP 2020 emphasises to foster a “democratic outlook and commitment to liberty and freedom; equality, justice, and fairness; embracing diversity, plurality, and inclusion; humaneness and fraternal spirit; social responsibility and the spirit of service; ethics of integrity and honesty; scientific temper and commitment to rational and public dialogue; peace; social action through Constitutional means; unity and integrity of the nation, and a true rootedness and pride in India with a forward-looking spirit to continuously improve as a nation.

NOTE-Refer to NCF-2023-Page no-320-323

In alignment with the NEP 2020, Social Science education seeks to develop responsible human beings capable of rational thought and action, possessing compassion, empathy, courage, resilience, scientific temper, and creative imagination — qualities that prepare them to contribute meaningfully to the nation and humanity.

Studying Social Science is essential for developing informed, empathetic, and active citizens. It enables learners to situate themselves within broader social, cultural and environmental contexts, and to recognise their role in shaping them. Through this subject, students understand the origins of democratic values, Constitutional principles, and India's civilisational ethos of unity in diversity. They also develop awareness of pressing issues such as inequality, conflict, environmental degradation and economic challenges, and learn to respond to them with evidence-based reasoning and ethical reflection. Social Science thus, bridges knowledge and action, encouraging learners to think critically about society and participate responsibly and effectively in it.

CURRICULAR GOALS-CG

As per NCF 2023 - At the Secondary Stage, students will go into details to understand India's past and appreciate its complexity, diversity, and unity brought about by cultural integration and the sharing of knowledge traditions across geographical and linguistic boundaries. NCF 2023 Page no -154

- CG-1 Understands and analyses the important phases in Indian history and draws insights to understand present-day India
- CG -2 Analyses the important phases in world history and draw insight to understand the present-day world
- CG-3 Understands the idea of a nation and the emergence of the modern Indian Nation
- CG -4 Develops an understanding of the inter-relationship between human beings and their physical environment and how that influences the livelihoods, cultural diversity, and biodiversity of the region
- CG -5 Understand the Indian Constitution and explores the essence of Indian democracy and the characteristics of a democratic government.
- CG -6 Understand and analyse social, cultural, and political life in India over time – as well as the underlying historical Indian ethos and philosophy of unity in diversity – and recognises challenges faced in these areas in the past and present and the efforts (being) made to address them
- CG -7 Develop an understanding of the inter-relationship between human beings and their physical environment and how that influences the livelihoods, cultural diversity, and biodiversity of the region
- CG -8 Evaluate the economic development of a country in terms of its impact on the lives of its people and nature
- CG-9 Understand and appreciate the contribution of India through history and present times, to the overall field of Social Science, and the disciplines that constitute it

COMPETENCIES

Competencies are specific learning achievements that are observable and can be assessed systematically. In NCF, Competencies are directly derived from a Curricular Goal and are

expected to be attained by the end of a Stage. The following competencies need to be developed in students to achieve the curricular goals at secondary stage.

- CG-1.1 Explains the historical events and processes using different types of sources with specific examples from Indian history
- CG-1.2 Explains and analyses the chronology of human life on the Indian subcontinent, from prehistory to its civilisational beginnings and beyond, and its relations with other civilisations over time, such as those in Mesopotamia, Greece, Central Asia, China, Southeast Asia, Arabia, and Eastern Africa
- CG-1.3 Traces aspects of continuity and change in different phases of history across the Indian subcontinent (including cultural trends, social and religious trends and reforms, and economic and political transformations)
- CG-1.4 Explains the growth of new indigenous ideas across India in Mathematics, Philosophy, Science and Technology, Medicine, Architecture, Agriculture, Literature and Art, and Social Science (such as zero and the Indian number system, *ahimsa*, the six systems of Indian philosophy, Ayurveda, yoga, the 22 *shrutis* of Indian music, horticulture, use of herbs and spices, etymology, meters, and grammar) and how they affected the course of the Indian history
- C-2.1 Explains historical events and processes with different types of sources with specific examples from India and world history.
- C-2.3 Traces aspects of continuity and change in different phases of world history (including cultural trends, social and religious reforms, and economic and political transformations)
- C-2.4 Explains the growth of new ideas and practices across the world (including humanism, mercantilism, industrialisation, scientific developments and explorations, imperialism, colonialism, the rise of the new nation states across the world, and various technologies including the most current) and how they affected the course of world history.
- C-2.5 Recognises the various practices that arose, such as those in C- 2.4, and came to be condemned later on (such as racism, slavery, colonial invasions, conquests, and plunder, genocides, exclusion of women from democratic and other institutions), all of which have also impacted the course of world history and have left unhealed wounds.
- C 3.1 Analyses the meaning of nation and how the concept evolved over time across the world and in the specific context of India, including its roots in the rich civilisational history of the Indian subcontinent
- C3.2 Identifies and analyses important phases of the Indian national freedom struggle against British colonial rule, with special reference to the movement led by Mahatma Gandhi and other important figures as well as those that led to independence, and understands the specific Indian concepts, values, and methods (such as Swaraj, Swadeshi, passive resistance, fight for dharma self- sacrifice, *ahimsa*) that played a part in achieving Independence.
- C-4.1 Locates physiographic regions of India and the climatic zones of the world on a globe/map.
- C-4.2 Explains important geographical concepts, characteristics of key landforms, their origin, and other physical factors of a region
- C-4.3 Draws inter- linkages between various components of the physical environment, such as climate and relief, climate and vegetation, vegetation, and wildlife.
- C-4.4 Analyses and evaluates the inter- relationship between the natural environment and human beings and their cultures across regions and, in the case of India, the special environmental ethos that resulted in practices of nature conservation

- C-4.5 Critically evaluates the impact of human interventions on the environment, including climate change, pollution, shortages of natural resources (particularly water), and loss of biodiversity; identifies practices that have led to these environmental crises and the measures that must be taken to reverse them.
- C-4.6 Develops sensitivity towards the judicious use of natural resources (by individuals, societies, and nations) and suggests measures for their conservation
- C-5.1 Understands that the Indian Constitution draws from the great cultural heritage and common aspirations of the Indian nation, and recalls India's early experiments with democracy (assemblies in *Mahajanapadas*, kingdoms and empires at several levels of the society, guilds *sanghas* and *ganas*, village councils and committees, *Uthiramerur* inscriptions)
- C-5.2 Appreciates fundamental Constitutional values and identify their significance for the prosperity of the Indian nation.
- C-5.3 Explains that fundamental rights are the most basic human rights, and they flourish when people also perform their fundamental duties
- C-5.4 Analyses the basic features of a democracy and democratic government – and its history in India and across the world – and compares this form of government with other forms of government.
- C-5.5- Analyses the critical role of non-state and non-market participants in the functioning of a democratic government and society, such as the media, civil society, socio-religious institutions, and community institutions
- C-6.1 Understands how the Indian ethos and the cultural integration across India did not attempt uniformity, but respected and promoted a rich diversity in Indian society, and how this harmonisation and unity in diversity, with a historical respect for all cultures, women have counted among India's great strengths by promoting peaceful coexistence
- C-6.2 Understands that despite C-6.1, forms of inequality, injustice, and discrimination have occurred in different sections of society at different times (due to internal as well as outside forces such as colonisation), leading to political, social, and cultural efforts, struggles, movements, and mechanisms at various levels towards equity, inclusion, justice, and harmony, with varying outcomes and degrees of success.
- C 6.3 Analyses aspects of differential treatment or discrimination that may exist in the Indian society, based on, socio-cultural background, region, language spoken, and what individuals and societies can do to eradicate such differential treatment
- C 6.4 Understands that a progressive society and nation, such as India is one that recognises not only its civilisational strengths but also its socio-economic, cultural and political challenges, and continuously makes efforts to address those challenges to become ever more prosperous, inclusive, just, and harmonious
- C-7.1 Defines key features of the economy, such as, production, distribution, demand, supply, trade, and commerce, and factors that influence these aspects (including technology)
- C-7.2 Evaluates the importance of the three sectors of production (primary, secondary, and tertiary) in any country's economy, especially India
- C-7.3 Distinguishes between 'unorganised' and 'organised' sectors of the economy and their role in production for the local market in small, medium, and large-scale production centres (industries), and recognises the special importance of the so-called 'unorganised' sector in

Indian economy and its connections with the self-organising features of Indian society

- C-7.4 Traces the beginning and importance of large- scale trade and commerce (including e- commerce) between one country and another - the key items of trade in the beginning, and the changes from time to time.
- C-8.1 Gathers, comprehends and analyses data related to income, capital, poverty, and employment in one's locality, region and at the national level. Markets.
- C- 8.2 Understands and analyses the concepts and practices of the range of economic systems — from free market to entirely state-controlled markets.
- C-8.3 Understands these features in the context of ancient India, with its thriving trade, both internal and external, and its well- established trade practices and networks, business conventions, and diverse industries, all of which made India one of the world's leading economies up to the colonial period
- C-8.4 Describes India's recent path towards again becoming one of the three largest economies of the world, and how individuals can contribute to this economic progress.
- C-8.5 Appreciates the connections between economic development and the environment, and the broader indicators of societal wellbeing beyond GDP growth and income.
- C – 9.1 Knows and explains the significant contributions of India to all matters (concepts, explanations, methods) studied within the curriculum, in an integrated manner

Pedagogy for teaching geography should integrate experiential, visual, and analytical approaches to make learning more meaningful and connected to the real world. Effective geography teaching goes beyond textbooks- it involves helping students observe, analyse, and interpret the Earth's surface and human-environment relationships. The use of three-dimensional models enables students to visualise complex geographical processes, such as mountain formation, river systems, and soil profiles, thus making abstract concepts tangible. Field observation is an essential pedagogical tool that promotes experiential learning; by directly engaging with local landscapes, students develop geographical inquiry skills, observation techniques, and data collection abilities. Incorporating Bhuvan images, India's indigenous satellite imagery and mapping platform allow learners to explore their own regions using real-time geospatial data and satellite views, linking classroom knowledge to local realities. Map reading is another fundamental component, as it cultivates spatial awareness, orientation, and the ability to interpret symbols, scales, and coordinates. Likewise, photo interpretation — analysing aerial and satellite photographs — helps students understand the land-use patterns, vegetation cover, urbanisation, and environmental changes. When combined, these methods foster critical thinking, spatial reasoning, and a deeper appreciation of the dynamic Earth systems that geography seeks to explain.

For understanding the past and India's rich heritage, teachers are expected to engage students in the following ways. Firstly, they are expected to analyse inscriptions or edicts (for example, Ashoka's edicts, and Gupta records) to understand how rulers communicated policies, messages, and ethical guidelines to their subjects. Secondly, they are to encourage students to read excerpts or chapters from Indian literary sources that throw light on the social, cultural, and political life of people. Thirdly, they are expected to conduct research and present examples of forts, temples, mosques, and palaces to illustrate cultural, architectural, and political developments in the Indian history. Finally, the teachers should explore and discuss the works of artists and philosophers of the Renaissance period, highlighting their contributions and influence.

Students should be made to locate the extent of various important empires on a world map. They are also expected to investigate and explain the key Indian ideas that shaped the thinking of Western philosophers, scientists, and artists. Finally, students should be encouraged to use a world map to trace India's trade and cultural exchanges with other civilisations, and analyse their patterns and impact.

Transaction of political concepts requires connecting students with evidence, inquiry, and real-world reasoning. Document-based inquiry helps learners explore authentic sources, such as Vedic texts, constitutional excerpts, and letters from national leaders to interpret historical contexts and moral reasoning. Case-based pedagogy, using landmark judgments, maps, and data analysis, builds decision-making and analytical skills, encouraging students to apply theory to practice. Evidence-based learning engages learners with real datasets from Census, NITI Aayog, or UNDP reports to develop data literacy and link concepts like equality and representation with measurable realities. Further, multimedia and experiential approaches use podcasts, documentaries, and archival materials to connect abstract political ideas with real experiences, sharpening students' interpretive and critical listening skills. Visual and graphic organiser-based pedagogy-through charts, tables, and concept maps — supports comprehension, memory, and summarisation by converting complex ideas into structured visuals. Together, these pedagogies transform classrooms into laboratories of civic thinking, empathy, and inquiry. They nurture students as reflective citizens who can interpret evidence, question assumptions, and engage meaningfully with India's democratic processes.

The pedagogy for teaching Economics needs to be interactive, experiential, and inquiry-driven, enabling students to relate economic concepts to real-life situations. Teachers can use role-play activities — such as running a lemonade stall or simulating the circular flow of income with students acting as households, firms, banks, and the government to make ideas like production, income, and expenditure tangible. Class discussions on familiar issues, such as rising vegetable prices during monsoons, help students link classroom learning with everyday experiences and develop critical thinking. Engaging classroom activities and games, like preparing a classroom budget, allow students to understand scarcity, choice, and opportunity cost in a fun and participatory way. The use of visual tools — including maps, pie charts, and graphs — can help students analyse data on GDP, trade, and sectoral trends. The case studies on topics like pollution as an externality, public goods like street lights, or successful entrepreneurs encourage application and deeper reflection. Surveys and field visits to local shopkeepers or MSMEs further bridge theory and practice by exposing students to real market dynamics. Incorporating current resources, such as newspaper articles or the Union Budget fosters analytical skills and awareness of contemporary economic issues. Through this diverse, hands-on approach, learners will move beyond memorisation to active understanding, making Economics relevant, engaging, and empowering

COURSE OUTLINE

Class IX-2026-27

Part 1

S. No.	Theme (time allocation in instructional hours)	Outline/Concepts	Learning Outcomes and Competencies Students will be able to:
1.	Understanding Social Science (4 Hours)	<ul style="list-style-type: none"> • Meaning, scope and relevance of Social Science • Understanding Social Science from an Indian perspective 	<ul style="list-style-type: none"> • Explain the relevance of studying Social Science to understand society, environment, economy, and governance in our lives. • Explain the meaning and scope of Geography, History, Political Science, and Economics as disciplines and recognise their interconnections. • Appreciate diversity, inclusivity, sustainability, and equity as guiding values when studying society and making decisions.
2.	Shaping of the Earth's Surface (8 Hours)	<ul style="list-style-type: none"> • Theory of plate tectonics • Interior of the Earth • Role of weathering and erosion; agents of gradation — river, waves and currents, wind, glaciers, and underground water • Landforms and disasters: earthquakes, landslides, avalanches, Glacial Lake Outburst Flood (GLOF) and duststorms 	<p>C4.2</p> <ul style="list-style-type: none"> • Describe the concept of plate tectonics and analyse its relevance in understanding Earth's dynamics. • Locate major tectonic plates on a world map. • Explain processes of weathering and erosion with suitable examples. • Identify the prominent agents of gradation operating in a given region. • Describe major landforms and explain the processes involved in their formation. • Explain the causes of natural disasters and propose strategies for their mitigation.
3.	Atmosphere and Climate (7 Hours)	<ul style="list-style-type: none"> • Structure and composition; elements of weather and climate • Seasons of India and monsoons • Climate change • Floods • Carbon footprint 	<p>C4.3, C4.4, C4.5</p> <ul style="list-style-type: none"> • Explain the different atmospheric layers and represent them using sketches and diagrams. • Observe and analyse local winds and their impact. • Understand the impact of the Indian monsoon on life, agriculture, and livelihoods across different regions.

			<ul style="list-style-type: none"> • Explain the causes and effects of climate change. • Represent climatic data (temperature, rainfall, etc.) through appropriate graphs, charts, or diagrams. • Analyse how climate change influences the frequency and intensity of natural disasters.
4.	Early Humans and Beginning of Civilisation (9 Hours)	<ul style="list-style-type: none"> • Cultural development from 2 million years ago • Early human history, periodisation: Archaeological ages • Who are human ancestors? • Palaeolithic hunter-gatherers and use of stone tools 	<p>C1.2, C2.1, C2.2, C2.3</p> <ul style="list-style-type: none"> • Describe how prehistoric time divisions are organised. • Explain how humans lived before the invention of writing • Understand the beginning of the settled life with development of agriculture, and domestication of plants and animals. • Explore the factors of urban development and transformation through time.
		<ul style="list-style-type: none"> • Mesolithic transition to food production: Mesolithic sites and tools • Neolithic and the beginning of farming: Neolithic revolution domestication of plants and animals • Harappan and contemporary cultures • Mesopotamian, egyptian, and chinese civilisation 	<ul style="list-style-type: none"> • Appreciate the diversity of crafts and trade, and their role the establishment of prosperous economy. • Understand the diversity of food habits. • Describe the social, political, and religious structures of the civilisations of Egypt and Mesopotamia.
5.	State and Society (upto 1000 CE) (9 Hours)	<ul style="list-style-type: none"> • Vedic Age — geography; texts; rituals; political institutions, and social order • Administrative structure of early empires • Quest for knowledge — educational heritage, institutions, knowledge traditions, and cultural practices 	<p>C1.3, C2.3, C3.1, C1.4</p> <ul style="list-style-type: none"> • Explain various facets of Vedic society and polity. • Appreciate the achievements of Indian empires and their cultural legacy. • Understand the knowledge traditions and practices of India. • Understand the foundations of the Indian social and political institutions and their continuity.

		<ul style="list-style-type: none"> • Traders and trade routes, guilds and merchants, crafts and industries 	
6.	Democracy (9 Hours)	<ul style="list-style-type: none"> • Meaning features and types of democracy • Roots of democracy in India • Challenges to democracy in India • Democratic systems in the world 	<p>C5.1, C5.2</p> <ul style="list-style-type: none"> • Understand the features of democracy. • Appreciate early democratic traditions in India and how they influenced modern democracy. • Differentiate between parliamentary and presidential systems. • Identify examples of both systems across countries, such as India, USA, France, Russia, and Canada.
7.	Elections (9 Hours)	<ul style="list-style-type: none"> • Factors of importance of elections • Electoral systems • Delimitation Commission • Election Commission of India and its role • Constituency, electoral rolls, enumerators • Party system in India 	<p>C5.2, C5.3, C5.4, C5.5, C6.2, C6.3, C6.4, C9.1</p> <ul style="list-style-type: none"> • Identify factors highlighting importance of elections in a democracy. • Categorise three types of electoral systems and list examples. • Identify the major laws that govern the conduct of elections in India. • Describe the main provisions of the Representation of the People Acts. • Define the concept of delimitation and its purpose in the Indian electoral system. • Identify the role and functions Election Commission of India (ECI) in the electoral process. • Explain constituency, electoral roll, enumerator. • Understand the party system in India. • Explain the meaning and features of a coalition government in the Indian political system. Explain key provisions of the Anti-Defection Law with reference to political instability and the need for anti-defection measures.
8.	Building Blocks in Economics (7 Hours)	<ul style="list-style-type: none"> • Scarcity of resources, opportunity cost and the need for making choice. What do economists do? 	<p>C8.2</p> <ul style="list-style-type: none"> • Explain the meaning of scarcity, choice, and opportunity cost in everyday life, and economic decision-making. • Describe what economists do and how they study production, distribution, and consumption of goods and services.

		<ul style="list-style-type: none"> • What to produce, how to produce, and for whom to produce? • Difference between market, centrally planned, and mixed economic systems • Welfare economy 	<ul style="list-style-type: none"> • Recognise how economic analysis helps in policy-making and solving real-world issues. • Describe the three central problems of an economy — what to produce, how to produce, and for whom to produce. • Identify and differentiate the characteristics of planned, free market, and mixed economic systems. • Explain the concept of a welfare economy and the importance of social safety nets.
9.	The Price Puzzle: What Drives the Market (8 Hours)	<ul style="list-style-type: none"> • Laws of demand and supply • Real-world deviations from textbook theory, such as in case of necessities, luxury goods, perishable items, and expectations • Some related concepts — price ceilings and market failures (externalities, information asymmetry, public goods) 	<p>C7.1</p> <ul style="list-style-type: none"> • Explain the Law of Demand and Law of Supply with the help of real life examples. • Interpret how changes in price affect the quantity demanded and quantity supplied of goods and services. • Identify the equilibrium price and quantity where demand and supply intersect. • Analyse how changes in market conditions (e.g., increase in demand or supply) lead to surplus or shortage and affect equilibrium. • Explain the concept of price ceilings and how they can lead to shortages or black markets. • Understand market failures and identify their main types. • Understand public goods (non-excludable and non-rival goods like parks or street lighting).

Part 2

S. No.	Theme (time allocation instructional hours)	Outline/Concepts	Learning Outcomes (pertinent) CGs, Cs Students will be able to:
1.	Oceans and Life (7 Hours)	<ul style="list-style-type: none"> • Introduction to ocean relief, movement of ocean water- waves, tides and currents • Marine resources and their significance; open seas, navigation fishing, and livelihood concerns and challenges • Cyclones and 	<p>C4.1, C4.2</p> <ul style="list-style-type: none"> • Explain the movement of ocean waters, including waves, tides, and currents. • Analyse the connections between ocean currents, and global and regional climate patterns. • Understand the importance of marine resources for human livelihoods and ecosystems. • Examine the relationship between oceans, climate, livelihoods, and natural disasters. • Highlight key rules, conventions, and

		<p>Tsunamis — early warning systems</p> <ul style="list-style-type: none"> • International maritime rules and regulations 	<p>international agreements governing ocean navigation. and the use of marine resources.</p> <ul style="list-style-type: none"> • Explain the need for international cooperation and agreements in the sustainable use of ocean resources. • Construct models or sketches representing ocean relief.
2.	Life on Earth (7 Hours)	<ul style="list-style-type: none"> • Biomes: Distribution and characteristics; biosphere reserves in India • Forest and ecotourism; forest dwellers, their livelihoods, and challenges • Forest and wildlife conservation • Government efforts to support forest dwellers 	<p>C4.3, C4.4, C4.5, C4.6</p> <ul style="list-style-type: none"> • Identify the major biomes of the world and describe their key climatic conditions, characteristic flora, and fauna. • Locate biosphere reserves on the map of India. • Appreciate local traditional practices related to biodiversity conservation and analyse their effects. • Explain the concept and importance of biosphere reserves in conserving ecosystems and biodiversity. • Analyse the concept of ecotourism and discuss its role in promoting sustainable forest ecosystem and conservation. • Investigate the causes of forest fires in the local area, and prepare a plan for mitigation and prevention.
3.	Resistance and Resilience (1000 CE – 1700 CE) (9 Hours)	<ul style="list-style-type: none"> • Safeguarding sovereignty: resistance, alliances and confederacies • Development of art and architecture, languages and literature • The Bhakti tradition • Forts and fortifications • Expansion of Indian economy and state 	<p>C1.3, C1.4, C3.1</p> <ul style="list-style-type: none"> • Explain the cultural, political, and military contributions of regional kingdoms in India. • Appreciate how diverse communities and regions shaped India’s history from 1000 CE to 1700 CE. • Explore how regional kingdoms adapted to changing political, economic, and cultural contexts over time. • Analyse the continuity of the civilisational history of India as a nation upto 18th century CE.
4.	India and the World-I (1900 BCE- 1200 CE) (8 Hours)	<ul style="list-style-type: none"> • Trade and commerce — trade with Mesopotamia, Greece, Roman Empire, China and Southeast Asia • Cultural Connections — Interactions with Greece and Rome, Central Asia, China, and Influence on South East Asia 	<p>C1.2, C1.4, C6.1, C2.3, C9.1</p> <ul style="list-style-type: none"> • Explore India’s relations with early civilisations of the world. • Identify the major articles of trade and the major trading ports. • Appreciate the significant contributions of India in diverse spheres in an integrated manner. • Appreciate the influence of Indian religion and culture, particularly in Southeast Asia.

		<ul style="list-style-type: none"> • Indian Knowledge Systems — Medicine, Mathematics and Astronomy, Medicine, Religion 	
5.	Authority (10 Hours)	<ul style="list-style-type: none"> • The Roots of Authority: in Kautilya and <i>shukraniti- danda</i> and relationship with <i>nyaya</i> and <i>bala</i>; the types of <i>nyaya</i> and <i>bala</i> • Constitutional status of justice and security since ancient times • Links the role of citizens with the elections and the democratic institutions • Types of authority — functional, sensitive, and welfare-oriented 	<p>C5.1, C5.2, C 5.3</p> <ul style="list-style-type: none"> • Explain the roots of authority in Indian political thought. • Interpret the relationship between <i>Danda</i> (discipline/ force) and <i>Nyaya</i> (justice) as the twin foundations of authority, development, and security. • Trace the evolution of authority structures in India. • Understand the post- independence concept of justice and security. • Illustrate types of authority. • Develop an understanding of citizen discipline, justice, and strength. • Illustrate the role of citizens in authority.
6.	From Ideas to Startups (8 Hours)	<ul style="list-style-type: none"> • What is entrepreneurship and explain the resources required to start a business • Case studies of successful entrepreneurs • Creative destruction with examples • Start-up ecosystem in India. • Make in India initiative, role of MSMEs and the unorganised sector in India's economic growth. • Stages of starting and executing a business idea through a business plan • Some basic accounting concepts 	<p>C7.3</p> <ul style="list-style-type: none"> • Define entrepreneurship and explain its importance in innovation, job creation, and economic growth. • Understand the key resources for business. • Explain how resources are managed to produce goods and services. • Analyse real-world examples of successful entrepreneurs. • Describe the features of India's start-up ecosystem and initiatives like Make in India, Startup India, and Digital India. • Recognise the role of Micro, Small, and Medium Enterprises (MSMEs) and the unorganised sector in promoting employment, innovation, and inclusive growth. • Identify and explain the stages of starting a business from developing an idea to creating and executing a business plan. • Understand simple profit and loss. Identify the key components of a balance.

7.	Smart Ways to Manage Your Finances (6 Hours)	<ul style="list-style-type: none"> • Relevance of personal financial management in daily life • Inflation and its impact on purchasing power • Simple vs. compound interest rate • Budgeting • Various savings and investment options like fixed deposit, stocks, bonds, mutual funds, etc. • Risk and insurance • Personal income tax 	CG8 <ul style="list-style-type: none"> • Explain what personal financial management means and why it is essential in everyday life. • Recognise how managing income, spending, saving, and investment helps achieve financial stability and long-term goals. • Explain the difference between simple interest and compound interest. • Prepare a simple personal or family budget showing income, expenditure, and savings. • Identify various savings and investment instruments. • Understand the relationship between risk and return in different investment types. • Understand the concept of income tax and why citizens are required to pay it.
----	--	---	--

Note-Course Structure will be provided shortly

CLASS IX (2025-26)
INTERNAL ASSESSMENT: 20 MARKS

Type of Assessment	Description	Marks
Periodic Assessment	Pen Paper Test	5
Multiple Assessment	Quiz, debate, role play, viva-voce, group discussion, visual expression, interactive bulletin boards, gallery walks, exit cards, concept maps, peer assessment, self- assessment etc. through interdisciplinary project , Report Writing on field visits, Commentaries/visual interpretations, site-map making	5
Subject Enrichment Activity	Project work (Interdisciplinary)	5
Portfolio	Classroom, work done (activities/assignments) reflections, narrations, journals etc. Achievements of the student in the subject throughout the year. Participation of the student in different activities like Heritage India quiz etc.	5

CLASS IX
PRESCRIBED TEXT BOOKS

S. No.	Name of the Book	Publisher
1	Social Science-Part 1	NCERT
2	Social Science-Part 2	NCERT

संस्कृतम्
कक्षा - नवमी (2026-27)
पाठ्यक्रमः परीक्षानिर्देशाश्च

भाष्यते व्यवहारादिषु प्रयुज्यते इति भाषा । मानवः स्वमनसि विद्यमानान्विचारान् भावनाः अनुभूतिं च अर्थयुक्तैः ध्वनिभिः लिखितसङ्केतैः च व्यक्तीकरोति सा भाषा । भाषा अभिप्रायप्रकटनस्य साधनम् । वस्तुतः लोके द्वयोः मनुष्ययोः मध्ये परस्परम् अवबोधनाय, भावग्रहणाय, भावविनिमयाय च भाषया विना न अन्यत् स्पष्टतमं सरलतमं च साधनं विद्यते । लोके बहव्यः भाषाः सन्ति यासु संस्कृतभाषा प्राचीनतमा समृद्धा च अस्ति । संस्कृतभाषायाम् एव सन्ति ऋग्यजुस्सामाथर्वाः इति चत्वारः वेदाः, शिक्षा, व्याकरणं, निरुक्तं, ज्योतिषं, छन्दः कल्पः चेति षडङ्गानि, चतुर्दशविद्याः, विज्ञानम्, आयुर्वेदः, योगशास्त्रादयः ग्रन्थाः । अतः संस्कृतं केवलं भाषा न अपितु किञ्चन जीवनदर्शनम् इति वर्तते । इयं विद्या (भाषा) भारतीयानां प्रतिष्ठात्मिका कामधेनुः समस्तज्ञानप्रदात्री, ऐक्यप्रदात्री, धर्मार्थकाममोक्षप्रदात्री च अस्ति । सृष्टेः आदितः अद्यावधिः यत् शिक्षणं ज्ञानविज्ञानं च अस्ति तत् सर्वम् अस्यां भाषायामेव सन्निहितम् अस्ति । अतिसूक्ष्मभावनां प्रकटयितुं स्पष्टीकर्तुं संस्कृतं विना नैव अन्यत्र विद्यते सामर्थ्यम् । भारतीयं सर्वस्वं विश्वस्य समग्रं तत्त्वं च अस्यां भाषायाम् अस्ति ।

संस्कृतस्य भाषावैज्ञानिकत्वम् – ऐतिहासिक-वर्णनात्मक-तुलनात्मकाध्ययन-द्वारा भाषायाः प्रकृतेः विकासोत्पत्तेः संरचनायाः अध्ययनपूर्वकं सर्वेषां विषयाणां सैद्धान्तिकः निर्णयः भाषाविज्ञानेन क्रियते । भाषाविज्ञान-नामकशास्त्रे शब्दानाम् उत्पत्तिः, वाक्यानां संरचना इत्यादीनां विषयाणां विचारः क्रियते । भाषाविज्ञानस्य सम्बन्धः सर्वेषां मानवानां भाषाभिः सह अस्ति । एवं भाषाविज्ञाने ध्वनेः, ध्वनि-उच्चारणोपयोगिनां स्वरयन्त्रमुखजिह्वादि-अङ्गानां प्रकृति-प्रत्ययादीनां, संज्ञासर्वनाम-क्रिया-विशेषणादीनां नामाख्यातोपसर्जननिपातानां पदपदार्थविषयकानां विकारादीनां विकारमूलककारकाणाम् अन्येषां विविधविषयाणाञ्च अध्ययनं क्रियते । भाषाविज्ञाने संस्कृतभाषा-विषयक-वर्णोत्पत्ति-सिद्धान्तस्य अतीव वैज्ञानिकं निरूपणं कृतं वर्तते ।

राष्ट्रीयशिक्षानीतौ (२०२०) इत्यत्र भाषा मानवसशक्तीकरणस्य आधारः साधनं वा अङ्गीकृतं वर्तते । भारतस्य परमविशिष्टस्य गतज्ञानवैभवस्य पुनः प्रतिष्ठापनमपि राष्ट्रियशिक्षानीतेः २०२० इत्यस्याः लक्ष्यमस्ति । एतदर्थं संस्कृतभाषयाः शिक्षणस्य महत्त्वम् इतोऽप्यधिकं भवति । प्रायः सर्वासु भाषासु संस्कृतपरकशब्दाः उपलभ्यन्ते । संस्कृतभाषा भारतीयभाषाणां जननी इति कथ्यते । सर्वासु भारतीयभाषासु संस्कृतभाषा अन्तर्लीना अस्ति इति सर्वे अङ्गीकुर्वन्ति ।

भारतदेशः बहुभाषी देशोऽस्ति । अस्मिन् देशे अनेकतायाम् एकतावर्धिनी भाषेयं सामाजिकसमरसतायै जीवनविकासाय च आवश्यकी वर्तते । संस्कृतस्य सांस्कृतिकं महत्त्वं वर्णयन्तः विद्वांसः कथयन्ति “भारतस्य प्रतिष्ठे द्वे संस्कृतं संस्कृतिस्तथा, संस्कृतिमूलं संस्कृतम्, साहित्यं संस्कृतिवाहकञ्च इति ।” एषा संस्कृतिः न केवलं भारतस्य अपि तु विश्वस्य मुकुटायमाना अस्ति । उक्तं च -

सत्यमहिंसादिगुणैः श्रेष्ठा विश्वबन्धुत्वशिक्षिका ।

विश्वशान्तिः सुखधात्री भारतीया हि संस्कृतिः ॥

संस्कृते संस्कृतिर्ज्ञेया संस्कृते सकलाः कलाः ।

संस्कृते सकलं ज्ञानं संस्कृते किन्न विद्यते ॥

एवं संस्कृतभाषा परिनिष्ठिता, दोषरहिता, सरला, गभीरा, यथार्था वैज्ञानिकी च भाषा अस्ति । सम्प्रति युगेऽस्मिन् प्रमुखैः उद्देश्यैः संस्कृतभाषा शिक्षणीया अस्ति ।

शिक्षणोद्देश्यानि –

भाषायाः प्रभावपूर्णसम्प्रेषणाय विविधानां मौखिकलेखनाभ्यासानां नवमाध्यमानां च प्रयोगः करणीयः भविष्यति ।

यथा - चर्चा भाषणानि सन्दर्शनानि निबन्धाः पत्रलेखनं विद्युन्मानपत्रं (email) दृश्यश्रव्यमाध्यमानि च इत्यादयः वर्तन्ते ।

- वसुधैव-कुटुम्बकम् इति भावनाविकासः ।
- भारतीयभाषाणां संरक्षणम् ।
- संस्कृतभाषया सम्प्रेषणकौशलविकासः ।
- परस्परं संस्कृतसम्भाषणेन भावविनिमयः ।
- संस्कृत-भाषया एव संस्कृत-शिक्षणम् ।
- श्रवण-भाषण-पठन-लेखनेति चतुर्णां भाषिक-कौशलानां विकासः ।
- बौद्धिकविकासपुरस्सरम् आध्यात्मिकनैतिकज्ञानम् ।
- निर्णयात्मिकायाः बुद्धेः विकासः ।
- तार्किकचिन्तनेन सह निर्भीकवक्तृत्वकौशलस्य विकासः ।
- मानसिकविकासानन्दानुभूतिः रसानुभूतिश्च ।
- भारतीयसंस्कृतेः संरक्षणं ज्ञानवर्धनञ्च ।
- आत्मानुशासनसंस्थापनार्थं शिक्षणम् ।
- सर्जनात्मकचिन्तनकौशलस्य विकासः ।
- सामाजिकचेतनायाः विकासः ।
- भाषाशिक्षणकौशलानि वर्धनाय नैपुण्यप्राप्तिः ।
- परस्परं वार्तालापमाध्यमेन भावविनिमयः ।
- संस्कृतसाहित्यस्य अध्ययनेन ज्ञानानन्दस्य अनुभूतिः ।
- मानवजीवनस्य विकासपूर्वकं कल्याणम् ।
- संस्कृतभाषया छात्राणां सर्वविधविकासः ।

शिक्षणप्रविधयः -

- संस्कृतमाध्यमेन सम्भाषणविधिना शनैः शनैः संस्कृतशिक्षणं सम्भविष्यति । गतिवर्धनाय संस्कृताध्यापकैः धैर्येण स्वकीयाध्यापन-कार्यक्रमाणां नियोजनम् । रुचिकरभाषाभ्यासेन भाषिकोपलब्धिः । भाषिकाभ्यासाय वार्तालाप-कथाश्रवण-वादविवाद-संवादादि-वर्णनपरकाभिः प्रतियोगिताभिः भाषाशिक्षणं कारयितुं शक्यते ।
- विभिन्नप्रामाणिकसंस्थानां कार्यक्रमाः साहित्यसामग्र्यश्च प्रयुज्य उत्तमशिक्षणं कर्तुं शक्यते ।
- संस्कृतभाषया उपलब्ध-दृश्य-श्रव्य-सामग्री-माध्यमेन भाषाभ्यासः ।
- आवश्यकतानुगुणं नवदृश्य-श्रव्य-सामग्री-निर्माण-माध्यमेन भाषायाः शिक्षणम् ।
- विभिन्नपाठ्यसामग्रीद्वारा शिक्षकः स्वकीयं शिक्षणकार्यं रुचिकरं कर्तुं शक्नोति ।
- भाषाशिक्षकः छात्रान् स्नेहपूर्वकम् (आत्मीयभावेन) पाठयेत् ।
- अद्यतनपूर्वकं साहित्यकोश-शब्दकोश-सन्दर्भग्रन्थानां सहायतया छात्राणां तत्परतां रुचिवर्धनं च ।
- प्राचीनार्वाचीनयोर्मध्ये समन्वयस्थापनद्वारा नूतनशिक्षणविधिभिश्च संस्कृतशिक्षणम् ।

कौशलानि-

- श्रवणकौशलम् – भावाधिग्रहणाय ध्वन्यात्मकं भाषायाः प्रथमं कौशलम् इदम् । अस्य साधनानि- गुरुमुखम्, आकाशवाणी, दूरवाणी, परिवारसदस्याः, समाजः, कक्षाः, ध्वनिमुद्रणयन्त्रम्, दूरदर्शनम् इत्यादीनि ।

- भाषणकौशलम्- भावाभिव्यक्तये ध्वन्यात्मकं भाषायाः इदं द्वितीयं कौशलम् । वाग्-रूपं भावप्रकटनम् एव भाषणम्, परिसरप्रभावेण आधारेण वा भाषणशक्तिः जायते ।
- पठनकौशलम् – भावाधिग्रहणाय लिप्यात्मकं भाषायाः तृतीयं कौशलम् इदम् । (अर्थग्रहणपूर्वकं स्पष्टरूप-वाचनम् इत्यर्थः)
- लेखनकौशलम्- भावाभिव्यक्तये लिप्यात्मकं भाषायाः चतुर्थं कौशलम् इदम् । (ध्वनिरूपे विद्यमानं भाषांशं लिपिरूपे अवतारणं लेखनम् इति उच्यते)
- ज्ञानात्मक-अवबोधनात्मक-अनुप्रयोगात्मक-विश्लेषणात्मक-संश्लेषणात्मक-मूल्याङ्कनात्मक-लक्षिताधिगमनविशेषाः ।

संस्कृतम्

कक्षा - नवमी (2026-27)

आहत्याङ्काः – 80+20

वार्षिकमूल्याङ्कनाय निर्मिते प्रश्नपत्रे चत्वारः खण्डाः भविष्यन्ति –

‘क’ खण्डः	अपठितावबोधनम्	10 अङ्काः
‘ख’ खण्डः	रचनात्मकार्यम्	15 अङ्काः
‘ग’ खण्डः	अनुप्रयुक्तव्याकरणम्	25 अङ्काः
‘घ’ खण्डः	पठितावबोधनम्	30 अङ्काः

खण्डानुसारं विषयाः मूल्यभारः च

क्र. सं.	विषयाः	प्रश्नप्रकाराः	मूल्यभारः
‘क’ खण्डः			
अपठितावबोधनम्			10 अङ्काः
1.	एकः गद्यांशः (80-100 शब्दपरिमितः)	अति-लघूत्तरात्मकौ दीर्घोत्तरात्मकौ शीर्षकम् (लघूत्तरात्मकः) भाषिककार्यम् (बहुविकल्पात्मकाः)	2×1=2 2×2=4 1×1=1 3×1=3
		पूर्णभारः	10 अङ्काः
‘ख’ खण्डः			
रचनात्मकार्यम्			15 अङ्काः
2.	सङ्केताधारितम् औपचारिकम् अथवा अनौपचारिकं पत्रलेखनम् (मञ्जूषायाः सहायतया रिक्तस्थानपूर्तिमाध्यमेन पूर्णं पत्रं लेखनीयम्)	निबन्धात्मकः	10×½=5
3.	चित्रवर्णनम् अथवा अनुच्छेदलेखनम्	निबन्धात्मकः	5
4.	संवादपूर्तिः / कथापूर्तिः	निबन्धात्मकः	10×½=5

	(मञ्जूषायाः सहायतया रिक्तस्थानपूर्तिमाध्यमेन पूर्णः संवादः / कथा लेखनीया)		
		पूर्णभारः	15 अङ्काः
‘ग’ खण्डः			
अनुप्रयुक्तव्याकरणम्			25 अङ्काः
5.	सन्धयः	लघूत्तरात्मकाः.	3×1=3
6.	कारक-उपपदविभक्तयः	बहुविकल्पात्मकाः	3×1=3
7.	शब्दरूपाणि	बहुविकल्पात्मकाः.	3×1=3
8.	धातुरूपाणि	बहुविकल्पात्मकाः.	3×1=3
9.	प्रत्ययाः	बहुविकल्पात्मकाः	3×1=3
10.	समासः	बहुविकल्पात्मकाः	3×1=3
11.	सङ्ख्या – १-१०० (१-४ केवलं प्रथमा-विभक्तौ)	लघूत्तरात्मकाः	3×1=3
12.	उच्चारणस्थानानि	लघूत्तरात्मकाः	4×½=2
13.	अव्ययानि	लघूत्तरात्मकाः	4×½=2
		पूर्णभारः	25 अङ्काः
‘घ’ खण्डः			
पठितावबोधनम्			30 अङ्काः
14.	गद्यांशः	अति-लघूत्तरात्मकौ दीर्घोत्तरात्मकौ लघूत्तरात्मकौ (भाषिककार्यम्)	2×½=1 2×1=2 2×1=2
15.	पद्यांशः	अति-लघूत्तरात्मकौ दीर्घोत्तरात्मकौ लघूत्तरात्मकौ (भाषिककार्यम्)	2×½=1 2×1=2 2×1=2
16.	नाट्यांशः	अति-लघूत्तरात्मकौ दीर्घोत्तरात्मकौ लघूत्तरात्मकौ (भाषिककार्यम्)	2×½=1 2×1=2 2×1=2
17.	प्रश्ननिर्माणम्	दीर्घोत्तरात्मकः	5×1=5
18.	अन्वयः अथवा भावार्थः	दीर्घोत्तरात्मकः	4×1=4
19.	पाठाधारित-कथापूर्तिः (मञ्जूषापदसहायतया रिक्तस्थानपूर्तिः)	निबन्धात्मकः	6×½=3
20.	प्रसङ्गानुकूलम् अर्थचयनम्	बहुविकल्पात्मकाः	3×1=3
		पूर्णभारः	30 अङ्काः

सम्पूर्णभारः 80 अङ्काः

प्रश्नपत्र-प्रारूपम् / संरचना
संस्कृतम्
कक्षा - नवमी (2026-27)

प्रश्नप्रकारः	प्रश्नानां सङ्ख्या	विभाग-सङ्ख्या	प्रतिप्रश्नम् अङ्कभारः	आहत्याङ्काः
अति-लघूत्तरात्मकाः 1 अङ्कः	2=2	1	1	2
अति-लघूत्तरात्मकाः ½ अङ्कः	2+2+2=6	3	½	3
बहुविकल्पात्मकाः 1 अङ्कः	3+3+3+3+3+3+3=21	7	1	21
लघूत्तरात्मकाः ½ अङ्कः	4+4=8	2	½	4
लघूत्तरात्मकाः 1 अङ्कः	1+3+3+2+2+2=13	6	1	13
दीर्घोत्तरात्मकाः 1 अङ्कः	2+2+2+5+4=15	5	1	15
दीर्घोत्तरात्मकाः 2 अङ्कौ	2=2	1	2	4
निबन्धात्मकाः 3 अङ्काः	1=1	1	3	3
निबन्धात्मकाः 5 अङ्काः	1+1+1=3	3	5	15
			आहत्याङ्काः	80

संस्कृतम्
कक्षा-नवमी (2026-27)
वार्षिकं मूल्याङ्कनम्

‘क’ खण्डः अपठितावबोधनम्		(10 अङ्काः)
1. एकः अपठितः गद्यांशः 80-100 शब्दपरिमितः गद्यांशः, सरलकथा वर्णनं वा ➤ एकपदेन पूर्णवाक्येन च अवबोधनात्मकं कार्यम् (2+4) ➤ शीर्षकलेखनम् (1) ➤ अनुच्छेदाधारितं भाषिकं कार्यम् (3) भाषिककार्याय तत्त्वानि - ✓ वाक्ये कर्तृ-क्रियापदचयनम् ✓ कर्तृ-क्रिया-अन्वितिः ✓ विशेषण-विशेष्यचयनम् ✓ पर्याय-विलोमपदचयनम् ✓ सर्वनामस्थाने संज्ञाप्रयोगः		10

‘ख’ खण्डः	
रचनात्मककार्यम्	
(15 अङ्काः)	
2. सङ्केताधारितम् औपचारिकम् अथवा अनौपचारिकं पत्रलेखनम् (मञ्जूषायाः सहायतया रिक्तस्थानपूर्तिमाध्यमेन पूर्णं पत्रं लेखनीयम्)	5
3. चित्राधारितं वर्णनम् अथवा अनुच्छेदलेखनम् (मञ्जूषायाः सहायतया चित्रवर्णनम् अनुच्छेदलेखनं वा करणीयम्)	5
4. संवादपूर्तिः / कथापूर्तिः (कथा छात्रस्तरानुगुणम् एव भवेत्।) (मञ्जूषायाः सहायतया रिक्तस्थानपूर्तिमाध्यमेन पूर्णः संवादः / कथा लेखनीया।)	5
‘ग’ खण्डः	
अनुप्रयुक्तव्याकरणम्	
(25 अङ्काः)	
5. सन्धिकार्यम् (1+1+1) ➤ स्वरसन्धिः - दीर्घः, गुणः, वृद्धिः, यण्, अयादि, पूर्वरूपम् ➤ व्यञ्जनसन्धिः -जश्त्वसन्धिः, ‘म्’ स्थाने अनुस्वारः, तुगागमः ➤ विसर्गसन्धिः - उत्त्वम्, विसर्गस्य सत्वम्, शत्वम्, षत्वम्, रत्वम्	3
6. कारक-उपपद-विभक्तयः ➤ द्वितीया - उभयतः, धिक्, परितः, समया, निकषा, प्रति, विना ➤ तृतीया - सह, साकम्, समम्, सार्धम्, विना, अलम्, सदृश, हीन ➤ चतुर्थी - रुच्, दा (यच्छ), नमः, कुप्, स्वस्ति ➤ पञ्चमी - विना, बहिः, भी, रक्ष्, ऋते ➤ षष्ठी - उपरि, अधः, पुरतः, पृष्ठतः, निर्धारणे ➤ सप्तमी- स्निह्, निपुणः, विश्वस्, पटु	3
7. शब्दरूपाणि ➤ पुँल्लिङ्गशब्दाः - बालकवत्, कविवत्, साधुवत्, पितृवत्, राजन्, भवत्, विद्वस्, गुणिन् ➤ स्त्रीलिङ्गशब्दाः - लतावत्, मतिवत्, नदीवत्, मातृवत्, धेनुवत् ➤ नपुंसकलिङ्गशब्दाः - फलवत्, वारि, जगत्, मनस्, चक्षुष् ➤ सर्वनामशब्दाः - तत्, इदम्, किम् (त्रिषु लिङ्गेषु), अस्मद्, युष्मद्	3
8. धातुरूपाणि ➤ परस्मैपदिनः - पठ्, गम्, वद्, भू, क्रीड्, नी, दृश्, शक्, ज्ञा, अस्, कृ, दा, क्री, श्रु, पा (पिब) (पञ्चसु लकारेषु) ➤ आत्मनेपदिनः - सेव्, लभ्, रुच्, मुद्, वृध् (लट्-लृट्-लोट्-लकारेषु) ➤ उभयपदिनः - कृ, पच्, नी, कृष्, ह, भज् (केवलं लट्लकारे)	3
9. प्रत्ययाः ➤ क्त्वा, तुमुन्, ल्यप्, क्त, क्तवतु, शतृ, शानच्	3

10. समासः – तत्पुरुषः (विभक्ति-नञ्-उपपद-कर्मधारय)	3
11. सङ्ख्या – 1-100 (1-4 केवलं प्रथमा-विभक्तौ)	3
12. उच्चारणस्थानानि	2
13. अव्ययानि	2
<ul style="list-style-type: none"> ➤ स्थानबोधकानि – अत्र, तत्र, अन्यत्र, सर्वत्र, यत्र, एकत्र, उभयत्र ➤ कालबोधकानि – यदा, तदा, सर्वदा, एकदा, पुरा, अधुना, अद्य, श्वः, ह्यः ➤ प्रश्नबोधकानि – किम्, कुत्र, कति, कदा, कुतः, कथम्, किमर्थम् ➤ अन्यानि – च, अपि, यदि, तर्हि, यथा, तथा, सम्यक्, एव, तु 	
‘घ’ खण्डः	
पठितावबोधनम्	
(30 अङ्काः)	
14. गद्यांशम् अधिकृत्य अवबोधनात्मकं कार्यम् प्रश्नप्रकाराः – एकपदेन पूर्णवाक्येन च प्रश्नोत्तराणि भाषिककार्यम् –	5
<ul style="list-style-type: none"> ➤ वाक्ये कर्तृ-क्रियापदचयनम् ➤ विशेषण-विशेष्यचयनम् ➤ पर्याय-विलोमपचयनम् ➤ सर्वनामस्थाने संज्ञाप्रयोगः 	
15. पद्यांशम् अधिकृत्य अवबोधनात्मकं कार्यम् प्रश्नप्रकाराः – एकपदेन पूर्णवाक्येन च प्रश्नोत्तराणि भाषिककार्यम् –	5
<ul style="list-style-type: none"> ➤ वाक्ये कर्तृ-क्रियापदचयनम् ➤ विशेषण-विशेष्यचयनम् ➤ पर्याय-विलोमपचयनम् ➤ सर्वनामस्थाने संज्ञाप्रयोगः 	
16. नाट्यांशम् अधिकृत्य अवबोधनात्मकं कार्यम् प्रश्नप्रकाराः – एकपदेन पूर्णवाक्येन च प्रश्नोत्तराणि भाषिककार्यम् –	5
<ul style="list-style-type: none"> ➤ वाक्ये कर्तृ-क्रियापदचयनम् ➤ विशेषण-विशेष्यचयनम् ➤ पर्याय-विलोमपचयनम् ➤ सर्वनामस्थाने संज्ञाप्रयोगः 	
17. वाक्येषु रेखाङ्कितपदानि अधिकृत्य उचितप्रश्ननिर्माणम्	5
18. अन्वयः अथवा भावार्थः (रिक्तस्थानपूर्तिः)	4
19. पाठाधारित-कथापूर्तिः (मञ्जूषापदसहायतया रिक्तस्थानपूर्तिः)	3
20. प्रसङ्गानुकूलम् अर्थचयनम्	3

परीक्षायै निर्धारिताः पाठाः – शीघ्रमेव सूचयिष्यन्ते

निर्धारितपाठ्यपुस्तकम् –

1. पाठ्यपुस्तकम् - शीघ्रमेव सूचयिष्यते
(प्रकाशनम् – रा.शै.अनु.प्र.परि. द्वारा)

अवधेयम् -

- * अनुप्रयुक्तव्याकरणस्य अंशानां चयनं यथासम्भवं 'पाठ्यपुस्तकात् करणीयम्।
- * पुस्तकपाठादिसहितं पूर्णः पाठ्यक्रमः शीघ्रमेव सूचयिष्यते।

नवमी

आन्तरिक-मूल्याङ्कनम् - 20 अङ्काः

उद्देश्यानि

- ❖ छात्राणां सृजनात्मकक्षमतायाः विकासः।
- ❖ श्रवण-भाषण-पठन-लेखनकौशलानां विकासः।
- ❖ चिन्तनक्षमतायाः आत्मविश्वासस्य च संवर्धनम्।

क्र. सं.	गतिविधयः	उदाहरणानि	अङ्काः	निर्देशाः	मूल्याङ्कनविन्दवः
1.	आवधिक-परीक्षा: (पीरियोडिक् - असैस्मैट)	लिखितपरीक्षा	05	विद्यालयेन समये समये लिखितपरीक्षाणाम् आयोजनं करणीयं भवति।	परीक्षासु यत्र विद्यार्थिनः श्रेष्ठाः अङ्काः स्युः तयोः द्वयोः परीक्षयोः एव अधिभारः ग्रहीतव्यः। अपि च आवधिकपरीक्षासु अपि प्रश्नेषु आन्तरिकविकल्पाः देयाः। मूल्याङ्कनसमये यदि छात्रः सर्वान् प्रश्नान् उत्तरति तर्हि छात्रहिताय यत्र अधिकाः अङ्काः सन्ति तेषाम् एव मूल्याङ्कनं करणीयम्।

2	बहुविधमूल्याङ्कनम्	<ul style="list-style-type: none"> ❖ कक्षायां पाठितस्य पाठस्य लघुमूल्याङ्कनम् ❖ निर्गतपत्राणि ❖ प्रश्नोत्तरी ❖ मौखिकी परीक्षा ❖ प्रतियोगिताः ❖ प्रश्नमञ्चस्यायोजनम् 	05	कक्षायां पाठित-पाठस्य विषयस्य वा बहुविधं मूल्याङ्कनम् अपेक्षितम् अस्ति । अनेन विद्यार्थिनां विविधकौशलानां मूल्याङ्कनं भवेत् ।	<ul style="list-style-type: none"> ❖ मौलिकता ❖ विषयसम्बद्धता ❖ शुद्धता ❖ समयबद्धता ❖ प्रस्तुतीकरणम्
3.	निवेशसूचिका (पोर्टफोलियो)	<ul style="list-style-type: none"> ❖ कक्षाकार्यम् ❖ सामूहिक-मूल्याङ्कनम् ❖ स्वमूल्याङ्कनम् ❖ विद्यार्थिनः विषयगताः उपलब्धयः 	05	विद्यार्थिभिः कक्षायां कृतानां कार्याणाम् उपलब्धीनां च संरक्षणं संयोजनं च सञ्चिकायां पत्रावल्यां वा करणीयम् । एतेन समग्रं मूल्याङ्कनं प्रमाणिकत्वेन भवितुं शक्नोति ।	<ul style="list-style-type: none"> ❖ सुलेखः ❖ तथ्यात्मकता ❖ प्रामाणिकता ❖ समयबद्धता
4.	भाषा-संवर्धनाय गतिविधयः (क) श्रवण-भाषण-कौशलम्	<ul style="list-style-type: none"> ❖ कथा ❖ संवादः/ वार्तालापः ❖ भाषणम् ❖ नाटकम् ❖ वार्ताः ❖ आशुभाषणम् ❖ संस्कृतगीतानि ❖ श्लोकोच्चारणम् ❖ प्रहेलिकाः 	05	<ul style="list-style-type: none"> ❖ छात्राः कामपि कथां श्रावयितुं शक्नुवन्ति । ❖ शिक्षकः कमपि विषयं सूचयित्वा परस्परं संवादं कारयितुं शक्नोति । ❖ दूरदर्शने वार्तावली इत्याख्यः संस्कृत-कार्यक्रमः प्रसारितः भवति तं द्रष्टुं छात्राः प्रेरणीयाः । ❖ श्रवण-कौशल-मूल्याङ्कनाय शिक्षकः स्वयम् अपि कथां श्रावयित्वा ततः सम्बद्ध-प्रश्नान् प्रष्टुं शक्नोति । 	<ul style="list-style-type: none"> ❖ उच्चारणम् ❖ शुद्धता ❖ समयबद्धता ❖ प्रस्तुतीकरणम् (आरोहावरोह-गतियति-प्रयोगः)
	(ख) लेखनकौशलम्	<ul style="list-style-type: none"> ❖ विविधविषयान् आधृत्य मौलिकलेखनम् यथा- देशः, माता, पिता, गुरुः, विद्या पर्यावरणम्, योगः, समयस्य सदुपयोगः, 		<ul style="list-style-type: none"> ❖ छात्राः यथाशक्यं कक्षायामेव लेखनकार्यं कुर्युः । ❖ टिप्पणी- पुस्तिकायाः निर्माणम् । ❖ वैयक्तिकपरीक्षणम् । 	<ul style="list-style-type: none"> ❖ विषय-सम्बद्धता ❖ शुद्धता (विशेषतः पञ्चमवर्णस्यप्रयोगः) ❖ समयबद्धता ❖ सुलेखः ❖ प्रस्तुतीकरणम्

		शिक्षा, अनुशासनम् इत्यादयः । ❖ शैक्षिकभ्रमणस्य संस्कृतेन प्रतिवेदनलेखनम् । ❖ दैनन्दिनीलेखनम् । ❖ सङ्केताधारितं कथालेखनम् । ❖ भित्तिपत्रिकायाः निर्माणम् । ❖ श्रुतलेखः । ❖ सूक्तिलेखनम् ।			
	अवधातव्यम् –उपर्युक्त-गतिविधयः उदाहरणरूपेण प्रदत्ताः सन्ति । एतदतिरिच्य एतादृशाः अन्यगतिविधयः अपि भवितुमर्हन्ति ।				

CBSE | DEPARTMENT OF SKILL EDUCATION

CURRICULUM FOR SESSION 2026-2027

EMPLOYABILITY SKILLS

(COMMON FOR ALL SKILL COURSES)

CLASS IX

UNIT NO.	UNIT NAME
UNIT 1	Communication Skills - I
UNIT 2	Self- Management Skills - I
UNIT 3	Information and Communication Technology Skills - I
UNIT 4	Entrepreneurial Skills- I
UNIT 5	Green Skills - I

UNIT 1: COMMUNICATION SKILLS – I

LEARNING OUTCOMES	THEORY	PRACTICAL
1. Demonstrate knowledge of various methods of communication	1. Methods of communication <ul style="list-style-type: none">- Verbal- Non-verbal- Visual	1. Writing pros and cons of written, verbal and non-verbal communication 2. Listing do's and don'ts for avoiding common body language mistakes
2. Identify elements of communication cycle	1. Meaning of communication 2. Importance of communication skills 3. Elements of communication cycle– <ul style="list-style-type: none">- sender,- ideas,- encoding,- communication channel,- receiver,- decoding, and- feedback	1. Draw a diagram of communication cycle 2. Role plays on communication process related to the sector/job role
3. Identify the factors affecting our perspectives in communication	1. Perspectives in communication 2. Factors affecting perspectives in communication <ul style="list-style-type: none">- Visual perception- Language- Past experience- Prejudices- Feelings- Environment	1. Group discussion on factors affecting perspectives in communication 2. Sharing of experiences on factors affecting perspectives 3. Sharing experiences on factors affecting communication at workplace

LEARNING OUTCOMES	THEORY	PRACTICAL
4. Demonstrate the knowledge of basic writing skills	1. Writing skills related to the following: <ul style="list-style-type: none"> - Phrases - Kinds of sentences - Parts of sentence - Parts of speech - Use of articles - Construction of a paragraph 	1. Demonstration and practice of writing sentences and paragraphs on topics related to the subject

UNIT 2: SELF-MANAGEMENT SKILLS – I

LEARNING OUTCOMES	THEORY	PRACTICAL
1. Describe the meaning and importance of self-management	1. Meaning of self-management 2. Positive results of self-management 3. Self-management skills	1. Identification of self-management skills 2. Strength and weakness analysis
2. Identify the factors that helps in building self-confidence	1. Factors that help in building self-confidence – social, cultural, and physical factors 2. Self-confidence building tips - getting rid of the negative thoughts, thinking positively, staying happy with small things, staying clean, hygienic and smart, chatting with positive people, etc.	1. Role play exercises on building self-confidence 2. Use of positive metaphors/ words 3. Positive stroking on wakeup and before going bed 4. Helping others and working for community

UNIT 3: INFORMATION AND COMMUNICATION TECHNOLOGY SKILLS – I

LEARNING OUTCOMES	THEORY	PRACTICAL
1. Describe the role of Information and Communication Technology (ICT) in day-to-day life and workplace	1. Introduction to ICT 2. Role and importance of ICT in personal life and at workplace 3. ICT in our daily life (examples) 4. ICT tools - Mobile, tab, radio, TV, email, etc.	1. Discussion on the role and importance of ICT in personal life and at workplace. 2. Preparing posters / collages for showing the role of ICT at workplace
2. Identify components of basic computer system and their functions	1. Computer system - Central Processing Unit (CPU), memory, motherboard, storage devices 2. Hardware and software of a computer system	1. Connecting the cables and peripherals to the Central Processing Unit 2. Starting and shutting down a computer

LEARNING OUTCOMES	THEORY	PRACTICAL
	3. Role and functions of Random Access Memory (RAM) and Read Only Memory (ROM) 4. Role and functions of Central Processing Unit 5. Procedure for starting and shutting down a computer	3. Group discussion on the various aspects of hardware and software
3. Demonstrate use of various components and peripherals of computer system	1. Peripherals devices and their uses – mouse, keyboard, scanner, webcam, etc. of a computer system	1. Identification of various parts and peripherals of a computer 2. Demonstration and practice on the use of mouse 3. Demonstration and practice on the use of keyboard 4. Demonstration of the uses of printers, webcams, scanner and other peripheral devices 5. Drawing diagram of computer system and labelling it
4. Demonstrate basic computer skills	1. Primary operations on a computer system – input, process, storage, output, communication networking, etc.	1. Identification of the various input and output units and explanation of their purposes

UNIT 4: ENTREPRENEURIAL SKILLS- I

LEARNING OUTCOMES	THEORY	PRACTICAL
1. Identify various types of business activities	1. Types of businesses – service, manufacturing, hybrid 2. Types of businesses found in our community Business activities around us	1. Prepare posters of business activities found in cities/villages, using pictures 2. Discuss the various types of activities, generally adopted by small businesses in a local community 3. Best out of waste 4. Costing of the product made out of waste 5. Selling of items made from waste materials 6. Prepare list of businesses that provides goods and services in exchange for money
2. Demonstrate the knowledge of distinguishing characteristics of entrepreneurship	1. Meaning of entrepreneurship development 2. Distinguishing characteristics of entrepreneurship	1. Prepare charts showing advantages of entrepreneurship over wages 2. Group discussions on role and features of entrepreneurship

LEARNING OUTCOMES	THEORY	PRACTICAL
	3. Role and rewards of entrepreneurship	3. Lectures/presentations by entrepreneurs on their experiences and success stories 4. Identify core skills of successful entrepreneur

UNIT 5: GREEN SKILLS – I

LEARNING OUTCOMES	THEORY	PRACTICAL
1. Demonstrated the knowledge of the factors =influencing natural resource conservation	1. Introduction to environment, 2. Relationship between society and environment, ecosystem and factors causing imbalance 3. Natural resource conservation 4. Environment protection and conservation	1. Group discussion on hazards of deteriorating environment 2. Prepare posters showing environment conservation 3. Discussion on various factors that influence our environment
2. Describe the importance of green economy and green skills	1. Definition of green economy 2. Importance of green economy	1. Discussion on the benefits of green skills and importance of green economy 2. Prepare a Poster showing the importance of green economy with the help of newspaper/ magazine cuttings

Suggested Textbook:

❖ **Employability Skills for class IX by NCERT**

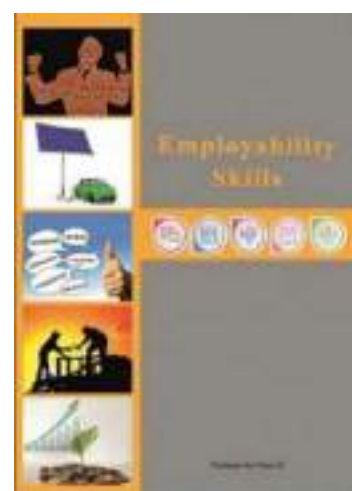

The textbook can be downloaded using any of the following links:

<http://psscive.ac.in/publications/textbooks>

<https://cbseacademic.nic.in/skill-education-books.html>

CBSE | DEPARTMENT OF SKILL EDUCATION

CURRICULUM FOR SESSION 2026-2027

INFORMATION TECHNOLOGY (SUB. CODE – 402)

JOB ROLE: DOMESTIC DATA ENTRY OPERATOR

CLASS – IX

COURSE OVERVIEW:

A Data Entry Operator/Analyst is a person who is responsible for entering data into different applications and computer databases, manage and maintain effective record keeping. In addition, S/he is responsible for organizing files, collecting and managing data to be entered into the computer. S/he is also responsible for security of data and safeguard of the computer network.

With every office and organization seeking to become computerized, the demand for data entry operators/analysts is on a rise. Data entry operators/analysts usually work in an indoor, office setting using a computer and other electronic machines. To be in the profession of data entry/analysis, one has to have computer literacy, high typing speed, organization skills, concentration skills, communication skills and an ability to sit for long periods of time entering and computing data.

OBJECTIVES OF THE COURSE:

In this course, the students will be introduced to the fundamental concepts of digital documentation, digital spreadsheet, digital presentation, database management and internet security.

The following are the main objectives of this course:

- To familiarize the students with the world of IT and IT enabled services.
- To provide an in-depth training in use of data entry, internet and internet tools.
- To develop practical knowledge of digital documentation, spreadsheets and presentation.
- To enable the students to understand database management system and have updated knowledge about digital record keeping.

- To make the students capable of getting employment in Private Sector, Public Sector, Ministries, Courts, House of Parliament and State Legislative Assemblies.
- To develop the following skills:
 - Data Entry and Keyboarding skills
 - The concept of Digital Documentation
 - The concept of Digital Presentation
 - The concept of Electronic Spreadsheet
 - The concept of Databases
 - Internet Technologies

SALIENT FEATURES

To be a data entry operator/analyst, one requires a lot of hard work and practical hands-on experience. One should have an intensive knowledge of Office applications, computer operations, and knowledge of clerical, administrative techniques and data analysis. Along with this, as a data entry operator/analyst, you will be expected to have fast typing speed, accuracy, and efficiency to perform tasks.

As a data entry operator/analyst, one should improve their computer skills, numerical and literacy skills. These skills can help one expand into a new career path in the future.

SCHEME OF UNITS

This course is a planned sequence of instructions consisting of units meant for developing employability and vocational competencies of students of Class IX opting for skill subject along with other education subjects. The unit-wise distribution of hours and marks for class IX is as follows:

INFORMATION TECHNOLOGY (SUBJECT CODE - 402)**CLASS – IX (Session 2026-2027)****Total Marks: 100 (Theory-50 + Practical-50)**

	UNITS	NO. OF HOURS for Theory and Practical		MAX. MARKS for Theory and Practical
Part A	Employability Skills			
	Unit 1 : Communication Skills-I	10		2
	Unit 2 : Self-Management Skills-I	10		3
	Unit 3 : ICT Skills-I	10		1
	Unit 4 : Entrepreneurial Skills-I	15		3
	Unit 5 : Green Skills-I	05		1
	Total		50	
Part B	Subject Specific Skills	Theory	Practical	Marks
	Unit 1: Introduction to IT- ITeS industry	2	4	4
	Unit 2: Data Entry & Keyboarding Skills	4	10	6
	Unit 3: Digital Documentation	10	26	10
	Unit 4:Electronic Spreadsheet	18	35	10
	Unit 5: Digital Presentation	10	31	10
	Total	44	106	
Part C	Practical Work			
	Practical Examination			15
	Written Test			10
	Viva Voce			10
	Total			
Part D	Project Work/ Field Visit			
	Practical File/ Student Portfolio			10
	Viva Voce			05
	Total			
	GRAND TOTAL	200		100

DETAILED CURRICULUM/TOPICS:

Part-A: EMPLOYABILITY SKILLS

S. No.	Units	Duration in Hours
1.	Unit 1: Communication Skills-I	10
2.	Unit 2: Self-Management Skills-I	10
3.	Unit 3: Basic Information and Communication Technology Skills-I	10
4.	Unit 4: Entrepreneurial Skills-I	15
5.	Unit 5: Green Skills-I	05
	TOTAL	50

NOTE: Detailed Curriculum/ Topics to be covered under Part A: Employability Skills can be downloaded from CBSE website.

Part-B – SUBJECT SPECIFIC SKILLS

- Unit 1: Introduction to IT- ITeS industry
- Unit 2: Data Entry & Keyboarding Skills
- Unit 3: Digital Documentation
- Unit 4: Electronic Spreadsheet
- Unit 5: Digital Presentation

UNIT 1: INTRODUCTION TO IT-ITeS INDUSTRY

S. No.	LEARNING OUTCOMES	THEORY	PRACTICAL
1	Appreciate the applications of IT	<ul style="list-style-type: none">• Introduction to IT and ITeS, BPO services,• BPM industry in India,• Structure of the IT-BPM industry,• Applications of IT in home computing, everyday life, library, workplace, education, entertainment, communication, business, science and engineering, banking, insurance, marketing, health care, IT in the government and public service	- Identify and list the various IT enabled services, Observe the application of IT in various areas.

UNIT 2: DATA ENTRY AND KEYBOARDING SKILLS

S. No.	LEARNING OUTCOMES	THEORY	PRACTICAL
1.	Use keyboard and mouse for data entry	<ul style="list-style-type: none"> • Keyboarding Skills, • Types of keys on keyboard, Numeric keypad, • Home keys, Guide keys, • Typing and deleting text, • Typing ergonomics, • Positioning of fingers on the keyboard, Allocation of keys to fingers on four different rows, • Pointing device – Mouse, Mouse operations. 	<ul style="list-style-type: none"> • Identify the keys and its use on the keyboard, • Demonstrate to use various keys on the keyboard, • Demonstrate to type the text, numbers, special character using appropriate keys on the keyboard, • Practice the correct typing ergonomics, • Practice to place fingers on correct key in four different row of keyboard, • Practice various mouse operations.
2.	Use typing software	<ul style="list-style-type: none"> • Introduction to Rapid Typing Tutor, • Touch typing technique, • User interface of Typing Tutor, • Typing text and interpret results, • Working with lesson editor, • Calculating typing speed, • Typing rhythm. 	<ul style="list-style-type: none"> • Identify the user interface of typing tutor, • Practice to type text in typing tutor software and interpret the results, • Practice to work in lesson editor, • Calculate the typing speed • Practice to improve typing • Using typing tutor software.

UNIT 3: DIGITAL DOCUMENTATION

S. No.	LEARNING OUTCOMES	THEORY	PRACTICAL
1.	Create a document using a word processor	<ul style="list-style-type: none"> • Introduction to word processing, • Word processing applications, • Introduction to Word Processing tool • Creating a document, Parts of a Word Processor Window, 	<ul style="list-style-type: none"> • List the available word processing applications. • Introduce with the parts of the main window. • Change document views. • Start a new document. • Open an existing document. • Save a document. • Close a document.
2.	Apply Editing features	<ul style="list-style-type: none"> • Text editing – Undo and Redo, • Moving and copying text, • Copy and Paste, • Selecting text, • Selection criteria, 	<ul style="list-style-type: none"> • Editing of text in a document • Demonstrate to use undo and redo option, • Use the keyboard and mouse options to select, cut, copy, paste, and move text.

S. No.	LEARNING OUTCOMES	THEORY	PRACTICAL
		<ul style="list-style-type: none"> • Selecting non-consecutive text items, • Selecting a vertical block of text, • Find and replace option, • Jumping to the page number, • Non-printing characters, • Checking spelling and grammar, • Using Synonyms and Thesaurus. 	<ul style="list-style-type: none"> • Demonstrate to select nonconsecutive text items, vertical block of text, • Search and replace text in a document. • Jump to the given page number in a document, • Insert non-printing characters in a document, • Apply Spelling and grammar option of document. • Demonstrate to use Synonyms and Thesaurus.
3.	Apply formatting features	<ul style="list-style-type: none"> • Page style dialog • Formatting text – Removing manual formatting, Common text formatting, Changing text case, Superscript and Subscript • Formatting paragraph – Indenting paragraphs, Aligning paragraphs, Font colour, highlighting, and background colour, Using bullets and numbering, Assigning colour, border and background to paragraph. • Page formatting – setting up basic page layout using styles, Inserting page break, Creating header/footer and page numbers, • Defining borders and backgrounds, Inserting images shapes, special characters in a document, Dividing page into columns, Formatting the shape or image. 	<ul style="list-style-type: none"> • Apply various text formatting options for the text, • Demonstrate to format paragraphs – indent/align paragraphs, assign font colour, highlighting, and background colour, • Assign number or bullets to the lists items • Demonstrate to assign colour, border and background to paragraph • Demonstrate the page formatting – set up basic page layout using styles, • Insert page break, Create header/footer and page numbers • Define borders and backgrounds • Insert images, shapes, special characters in a document • Divide page into columns, • Format the shape or image.
4.	Create and work with tables	<ul style="list-style-type: none"> • Creating table in Word Processor • Inserting row and column in a table • Deleting rows and columns • Splitting and merging tables • Deleting a table • Copying a table • Moving a table. 	<ul style="list-style-type: none"> • Demonstrate and do the following in Word Processor: • Create table, • Insert and delete rows and column in a table, • Split and merge tables, • Delete a table, • Copy or move from one location to another location of document.

S. No.	LEARNING OUTCOMES	THEORY	PRACTICAL
5.	Use Print Options	<ul style="list-style-type: none"> • Printing options in Word Processor. • Print preview, • Controlling printing, • Printing all pages, single and multiple pages. 	<ul style="list-style-type: none"> • Demonstrate to print the document, selected pages in the document • Print the document with various options, • Preview pages before printing.
6.	Understand and apply mail merge	<ul style="list-style-type: none"> • Introduction to mail merge • Concept of data source for mail merge. 	<ul style="list-style-type: none"> • Demonstrate to print the letters using mail merge, • Do the following to achieve • Create a main document, • Create the data source, • Enter data in the fields, • Merge the data source with main document, • Edit individual document, • Print the merged letter, • Save the merged letter.

UNIT 4: ELECTRONIC SPREADSHEET

S. No.	LEARNING OUTCOMES	THEORY	PRACTICAL
1.	Create a Spreadsheet	<ul style="list-style-type: none"> • Introduction to spreadsheet application • Starting a spreadsheet • Parts of a spreadsheet • Worksheet – Rows and Columns, Cell and Cell Address, • Range of cells – column range, row range, row and column range. 	<ul style="list-style-type: none"> • Start the spreadsheet, • Identify the parts of Calc, • Identify the rows number, column number, cell address, • Define the range of cell, • Identify row range, column range, row & column range
2.	Apply formula and functions in spreadsheet	<ul style="list-style-type: none"> • Different types of data, • Entering data – Label, Values, Formula • Formula, how to enter formula, • Mathematical operators used in formulae, • Simple calculations using values and operators, • Formulae with cell addresses and operators, • Commonly used basic functions in a spreadsheet – SUM, AVERAGE, MAX, MIN, Count • Use of functions to do calculations. 	<ul style="list-style-type: none"> • Demonstrate to enter the text, numeric data in a cell, • Identify the label, values and formula in the cell, • Demonstrate to enter formula in a cell, • Construct the formula using mathematical operators, • Identify formulae with cell addresses and operators, • Identify the correct syntax of formula, • Use the basic functions to perform calculations on data.

S. No.	LEARNING OUTCOMES	THEORY	PRACTICAL
3.	Format data in the spreadsheet	<ul style="list-style-type: none"> • Formatting tool, • Use of dialog boxes to format values, • Formatting a range of cells with decimal places, • Formatting a range of cells to be seen as labels, • Formatting of a cell range as scientific, • Formatting a range of cells to display times, • Formatting alignment of a cell range, • Speeding up data entry using the fill handle, • Uses of fill handle to copy formulae. 	<ul style="list-style-type: none"> • Identify the formatting tool, • Demonstrate to use of dialog boxes to format values, • Demonstrate to format range of cells with decimal places, • Demonstrate to format a range of cells to labels, • Demonstrate to format of a cell range as scientific, • Demonstrate to format a range of cells to display time, • Demonstrate to align cell data range, • Demonstrate to create number series using fill handle, • Copy formula by dragging the formula using fill handle.
4.	Understand and apply Referencing	<ul style="list-style-type: none"> • Concept of referencing, • Relative referencing, • Mixed referencing, • Absolute referencing. 	<ul style="list-style-type: none"> • Demonstrate to use Relative referencing in spreadsheet, • Demonstrate to use Mixed referencing in spreadsheet, • Demonstrate to use Absolute referencing in spreadsheet.
5.	Create and insert different types of charts in a spreadsheet	<ul style="list-style-type: none"> • Importance of chart in spreadsheet • Types of chart 	<ul style="list-style-type: none"> • Create different types of charts supported by a spreadsheet, • Illustrate the example of chart in a spreadsheet.

UNIT 5: DIGITAL PRESENTATION

S. No.	LEARNING OUTCOMES	THEORY	PRACTICAL
1.	Understand features of an effective presentation	<ul style="list-style-type: none"> • Concept of presentation, • Elements of presentation, • Characteristics of an effective presentation 	<ul style="list-style-type: none"> • Identify and list the elements of presentation, • List the characteristics of an effective presentation.
2.	Create a presentation	<ul style="list-style-type: none"> • Introduction to presentation software, • Opening a presentation software • Parts of presentation window, • Closing a presentation • Creating a presentation using template, • Selecting slide layout, • Saving a presentation, • Running a slide show, • Save a presentation in PDF, • Closing a presentation, • Using Help. 	<ul style="list-style-type: none"> • Start the presentation application • various components of main Impress window • Observe the different workspace views. • Create a new presentation using wizard. • Run the presentation, • Save the presentation, • Close the presentation, • Demonstrate to use Help in presentation.

S. No.	LEARNING OUTCOMES	THEORY	PRACTICAL
3.	Work with slides	<ul style="list-style-type: none"> • Inserting a duplicate slide, • Inserting new slides, • Slide layout, • Copying and moving slides, • Deleting and renaming slides • Copying, moving and deleting contents of slide, • View a presentation, • Controlling the size of the view, • Workspace views – Normal, Outline, Notes, Slide sorter view. 	<ul style="list-style-type: none"> • Demonstrate to insert a new slide and duplicate slide in a presentation, • Change the slide layout, • Demonstrate to copy and move slides in the presentation, • Demonstrate to copy, move and delete contents of the slide, • Demonstrate to view a presentation in different views.
4.	Format text and apply animations	<ul style="list-style-type: none"> • Formatting toolbar, • Various formatting features, • Text alignment, • Bullets and numbering. • Custom Animation 	<ul style="list-style-type: none"> • Identify and list the various options in formatting toolbar, • Apply the appropriate formatting option • Align the text in presentation, • Apply bullets and numbering to the list items in presentation • Apply Animation
5.	Create and use tables	<ul style="list-style-type: none"> • Inserting tables in presentation, • Entering and editing data in a table, • Selecting a cell, row, column, table, • Adjusting column width and row height, • Table borders and background 	<p>Demonstrate the following:</p> <ul style="list-style-type: none"> • Insert table in presentation, • Enter and edit data in a table, • Select a cell, row, column, table, • Adjust column width and row height, • Assign table borders and background.
6.	Insert and format image in presentation	<ul style="list-style-type: none"> • Inserting an image from a file, • Inserting an image from the gallery, • Formatting images, • Moving images, • Resizing images, • Rotating images, • Formatting using the Image toolbar, • Drawing graphic objects – line, shapes, • Grouping and un-grouping objects 	<ul style="list-style-type: none"> • Demonstrate to insert an image from file, gallery in presentation, • Apply formatting options to image in presentation, • Demonstrate to move, resize and rotate images, • Apply formatting options of Image toolbar, • Drawing line, shapes using graphic objects, <p>Demonstrate to group and ungroup objects.</p>
7.	Work with slide master	<ul style="list-style-type: none"> • Slide masters, • Creating the slide masters, • Applying the slide masters to all slide, • Adding transitions. 	<ul style="list-style-type: none"> • Create the slide masters, • Apply the slide masters to the presentation, • Add transitions to presentation.

LIST OF EQUIPMENT/ MATERIALS:

The list given below is suggestive and an exhaustive list should be compiled by the teacher(s) teaching the subject. Only basic tools, equipment and accessories should be procured by the Institution so that the routine tasks can be performed by the students regularly for practice and acquiring adequate practical experience.

S. No.	ITEM NAME, DESCRIPTION & SPECIFICATION	QUANTITY
A	HARDWARE	
1.	Computer with latest configuration or minimum Pentium Processor with minimum 2GB RAM, 512 GB HDD, 17” LED Monitor, NIC Card, 3 button Mouse, 105 keys key board and built-in speakers and mic.	15
2.	Laser Printer - Black	01
3.	Inkjet Printers (Colour & Black)	01
4.	Scanner	01
5.	Online UPS 5 KVA	01
6.	16 Port Switches	01
7.	Air Conditioner 1.5 tonne	02
8.	Telephone line (For Internet)	01
9.	Fire extinguisher	01
B	SOFTWARE	
1.	Operating System Linux and Windows	
2.	Anti-Virus Latest version	
3.	Productivity Suite, Example –Libre Office	
C	FURNITURE	
1.	Class room chairs and desks	25
2.	Computer Tables	15
3.	Straight back revolving & adjustable chairs (Computer Chairs)	15
4.	Printer Tables	02
5.	Trainers Table	01
6.	Trainers Chair	01
7.	Steel cupboards drawer type	02
8.	Cabinet with drawer	01
9.	Steel Almira - big size	01
10.	Steel Almira- small size	01

TEACHER'S/ TRAINER'S QUALIFICATIONS:

Qualification and other requirements for appointment of teachers/trainers for teaching this subject, on contractual basis should be decided by the State/ UT. The suggestive qualifications and minimum competencies for the teacher should be as follows:

Qualification	Minimum Competencies	Age Limit
Diploma in Computer Science/ Information Technology OR Bachelor Degree in Computer Application/ Science/ Information Technology (BCA, B.Sc. Computer Science/ Information Technology) OR Graduate with PGDCA OR DOEACC A Level Certificate. The suggested qualification is the minimum criteria. However higher qualifications will also be acceptable.	<ul style="list-style-type: none"> The candidate should have a minimum of 1 year of work experience in the same job role. S/he should be able to communicate in English and local language. S/he should have knowledge of equipment, tools, material, Safety, Health & Hygiene. 	<ul style="list-style-type: none"> 18-37 years (as on Jan. 01 (year)) Age relaxation to be provided as per Govt. rules

Teachers/Trainers form the backbone of Skill (Vocational) Education being imparted as an integral part of Rashtriya Madhyamik Shiksha *Abhiyan* (RMSA). They are directly involved in teaching of Skill (vocational) subjects and also serve as a link between the industry and the schools for arranging industry visits, On-the-Job Training (OJT) and placement.

These guidelines have been prepared with an aim to help and guide the States in engaging quality Teachers/Trainers in the schools. Various parameters that need to be looked into while engaging the Vocational Teachers/Trainers are mode and procedure of selection of Teachers/ Trainers, Educational Qualifications, Industry Experience, and Certification/ Accreditation.

The State may engage Teachers/Trainers in schools approved under the component of scheme of Vocationalisation of Secondary and Higher Secondary Education under RMSA in following ways:

- (i) Directly as per the prescribed qualifications and industry experience suggested by the PSS Central Institute of Vocational Education (PSSCIVE), NCERT or the respective Sector Skill Council (SSC).
- OR**
- (ii) Through accredited Vocational Training Providers accredited under the National Quality Assurance Framework (NQAF*) approved by the National Skill Qualification Committee on 21.07.2016. If the State is engaging Vocational Teachers/Trainers through the Vocational Training Provider (VTP), it should ensure that VTP should have been accredited at NQAF Level 2 or higher.

** The National Quality Assurance Framework (NQAF) provides the benchmarks or quality criteria which the different organizations involved in education and training must meet in order to be accredited by competent bodies to provide government- funded education and training/skills activities. This is applicable to all organizations offering NSQF-compliant qualifications.*

The educational qualifications required for being a Teacher/Trainer for a particular job role are clearly mentioned in the curriculum for the particular NSQF compliant job role. The State should ensure that teachers/trainers deployed in the schools have relevant technical competencies for the NSQF qualification being delivered. Teachers/Trainers preferably should be certified by the concerned Sector Skill Council for the particular Qualification Pack/Job role which he will be teaching. Copies of relevant certificates and/or record of experience of the teacher/trainer in the industry should be kept as record.

To ensure the quality of the Teachers/Trainers, the State should ensure that a standardized procedure for selection of (Vocational) Teachers/Trainers is followed. The selection procedure should consist of the following:

- (i) Written test for the technical/domain specific knowledge related to the sector;
- (ii) Interview for assessing the knowledge, interests and aptitude of trainer through a panel of experts from the field and state representatives; and (iii) Practical test/mock test in classroom/workshop/laboratory.

In case of appointment through VTPs, the selection may be done based on the above procedure by a committee having representatives of both the State Government and the VTP.

The State should ensure that the Teachers/ Trainers who are recruited should undergo induction training of 20 days for understanding the scheme, NSQF framework and Vocational Pedagogy before being deployed in the schools.

The State should ensure that the existing trainers undergo in-service training of 5 days every year to make them aware of the relevant and new techniques/approaches in their sector and understand the latest trends and policy reforms in vocational education.

The Head Master/Principal of the school where the scheme is being implemented should facilitate and ensure that the (Vocational) Teachers/Trainers:

- Prepare session plans and deliver sessions which have a clear and relevant purpose and which engage the students;
- Deliver education and training activities to students, based on the curriculum to achieve the learning outcomes;
- Make effective use of learning aids and ICT tools during the classroom sessions;
- Engage students in learning activities, which include a mix of different methodologies, such as project based work, team work, practical and simulation based learning experiences;
- Work with the institution's management to organise skill demonstrations, site visits, on job trainings, and presentations for students in cooperation with industry, enterprises and other workplaces;
- Identify the weaknesses of students and assist them in up-gradation of competency;
- Cater to different learning styles and level of ability of students;
- Assess the learning needs and abilities, when working with students with different abilities
- Identify any additional support the student may need and help to make special arrangements for that support;
- Provide placement assistance

Assessment and evaluation of (Vocational) Teachers/Trainers is very critical for making them aware of their performance and for suggesting corrective actions. The States/UTs should ensure that the performance of the (Vocational) Teachers/Trainers is appraised annually. Performance based appraisal in relation to certain pre-established criteria and objectives should be done periodically to ensure the quality of the (Vocational) Teachers/Trainers.

Following parameters may be considered during the appraisal process:

- Participation in guidance and counseling activities conducted at Institutional, District and State level;
- Adoption of innovative teaching and training methods;
- Improvement in result of vocational students of Class X or Class XII;
- Continuous up-gradation of knowledge and skills related to the vocational pedagogy, communication skills and vocational subject;
- Membership of professional society at District, State, Regional, National and International level;
- Development of teaching-learning materials in the subject area;
- Efforts made in developing linkages with the Industry/Establishments;
- Efforts made towards involving the local community in Vocational Education
- Publication of papers in National and International Journals;
- Organization of activities for promotion of vocational subjects;
- Involvement in placement of students/student support services.